



Electronic Service Manuals

This electronic document is provided as a service to our customers. We do not create the contents of the information contained in this document. Should you have detailed questions pertaining to the information contained in this document, you may contact Michco, or the manufacturer which provided the original information in this electronic deliverable. Michco's only part in this electronic deliverable was the electronic assembly process.

You may contact Michco through the following methods:
Phone (517) 484-9312 or (800) 331-3339 MI, OH, IN only
2011 N. High St. -- Lansing, Michigan -- 48906
Fax: (517) 484-9836
Email: CustServ@Michco.com
Web site: www.Michco.Com
Parts Web site: www.FloorMachineParts.Com

Order Parts on Line at:
www.FloorMachineParts.Com

Directly to Parts & Service:
By Email: **Shop@Michco.com**
By Fax: (517) 702-2041
By Voice: Use numbers above.

Serving the Cleaning Industry Since 1922

Notice: All copyrighted material remains property of original owners, all trademarks are property of respective owners. Manuals are subject to Manufacturer's reproduction limitations. Originals or reproductions were provided by manufacturers through a request. We make no warranty as to the correctness of information provided in this document and you assume all risk.

Carpetwin™ 14 / 18

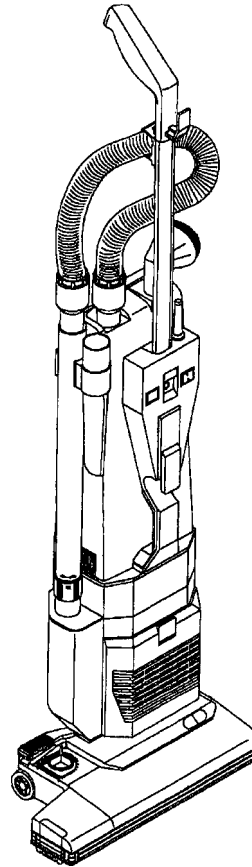

OPERATOR MANUAL AND PARTS LIST

Advance MODELS 56704200, 56704201



Advance
by Nilfisk-Advance

5/99 revised 11/02 Form Number 56041453

A

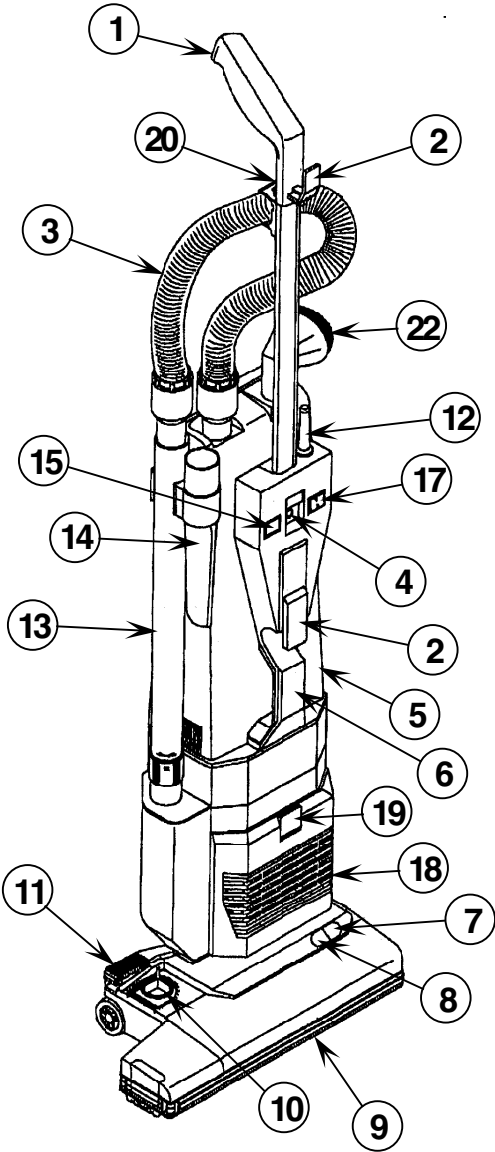

B

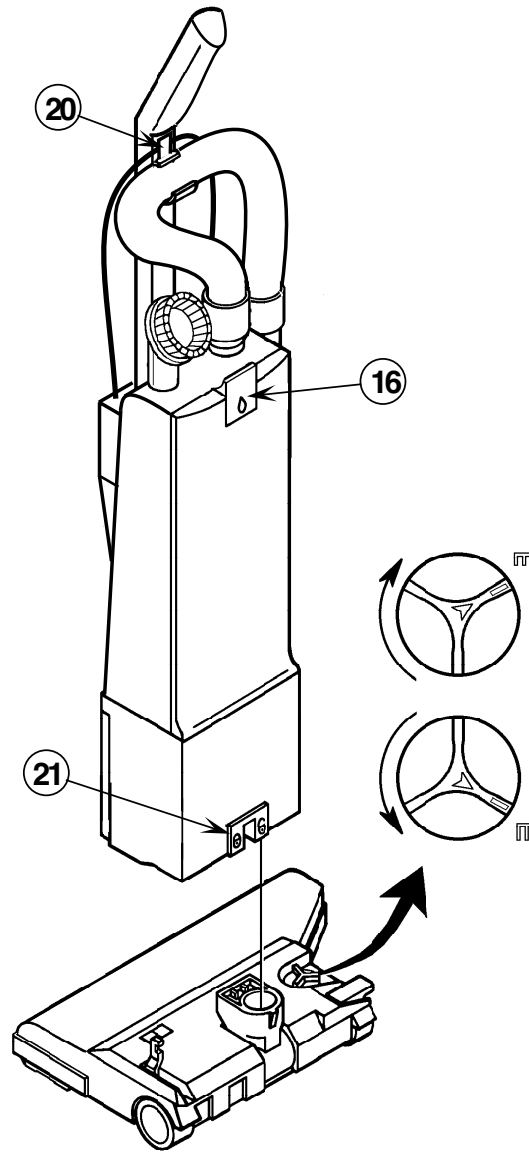

C

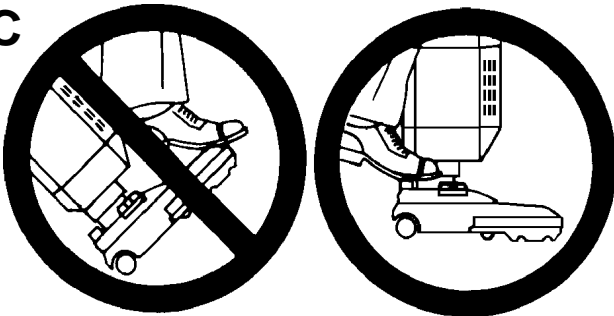

D

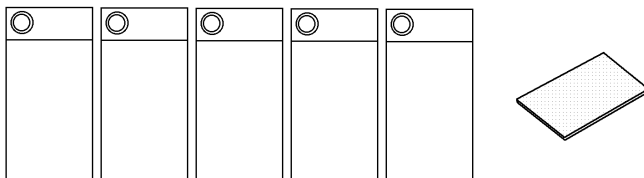

Important Safety Instructions 2
 Grounding Instructions 5
 Introduction 7
 Parts and Service 7
 Nameplate 7
 Unpacking the Machine 7
 Know Your Machine 7
 Set-Up and Assembly 7
 Operating the Machine 8
 Using the Wand 8
 After Using the Machine 8
 Vacuum Motor Brushes 8
 Maintenance 8
 Changing the Paper Dust Bag 8
 Changing the Cloth Dust Bag 8
 Cleaning the Vacuum Inlet Filter 9
 Changing the Electrostat Exhaust Filter 9
 Changing the Brush 9
 Replacing the Belt 9
 Technical Specifications 9
 Bag Housing Parts List 11-12
 Brush Housing Parts List 13-14
 Wiring Diagram 15

IMPORTANT SAFETY INSTRUCTIONS

When using an electrical appliance, basic precautions should always be followed, including the following:

Read all instructions before using.

This machine is for commercial use, for example in hotels, schools, hospitals, factories, shops and offices other than normal residential housekeeping purposes.

THIS APPLIANCE IS INTENDED FOR DRY USE ONLY!

DO NOT USE FOR WET FLOOR OR CARPET!

WARNING !

To reduce the risk of fire, electric shock, or injury:

- * Do not leave the appliance when it is plugged in. Unplug the unit from the outlet when not in use and before servicing.

WARNING !

To reduce the risk of electric shock, do not use outdoors or on wet surfaces.

- * Do not allow to be used as a toy. Close attention is necessary when used by or near children.
- * Use only as described in this manual. Use only the manufacturer's recommended attachments.
- * If the appliance is not working as it should be, has been dropped, damaged, left outdoors or dropped into water, return it to a service center. The machine must not be used if the electrical cord shows any sign of damage. Regularly inspect the cord for damage, particularly if it has been crushed, shut in a door or run over.
- * Do not pull or carry by the cord, use the cord as a handle, or pull the cord around sharp edges or corners. Keep the cord away from heated surfaces.
- * Do not unplug by pulling on the cord. To unplug, grasp the plug, not the cord.
- * Do not handle the plug, cord or appliance with wet hands.
- * Do not put any object into openings. Do not use with any opening blocked.
- * Keep loose clothing, hair, fingers, and all parts of body away from openings and moving parts.
- * Do not pick up anything that is burning or smoking, such as cigarettes or matches. Under no circumstances should the machine be used for picking up hot material. In particular the machine must not be used for cleaning open and closed fireplaces, ovens or similar that contain warm or glowing ashes.
- * Do not use without dust bag and/or filters in place.
- * Turn off all controls before unplugging. The plug must always be removed from the socket outlet before starting any service or repair work of the vacuum cleaner or the cord.
- * Avoid vacuuming hard or sharp objects.
- * Use extra care when cleaning on stairs.
- * The machine must not be used for picking up combustible materials which are health endangering or explosive materials such as petrol (gasoline), nor should it be used in an explosive atmosphere. The machine must not be used for picking up water, other liquids or for picking up hazardous - i.e. poisonous dust.
- * No changes or modifications of the mechanical, electrical or thermal safety devices should be made.
- * When repairing or replacing the cord, the same type of cord as originally supplied with the machine must be used. This cord can be supplied by ADVANCE.

SAVE THESE INSTRUCTIONS

INSTRUCTIONS DE SÉCURITÉ IMPORTANTES

Toujours suivre certaines précautions élémentaires lors de l'utilisation d'un appareil électrique.
Lire toutes les instructions avant d'utiliser la machine.

Cette machine est adaptée à l'usage commercial, par exemple dans les hôtels, les écoles, les hôpitaux, les usines, les magasins et les bureaux.

**CET APPAREIL NE DOIT ETRE UTILISE QU'A SEC!
NE PAS UTILISER SUR UNE SURFACE HUMIDE!**

⚠ AVERTISSEMENT !

Pour réduire les risques d'incendie, de décharge électrique ou de blessures:

- * Ne pas abandonner l'appareil s'il est branché. Débrancher l'alimentation secteur quand l'appareil n'est pas utilisé ou avant l'entretien.

⚠ AVERTISSEMENT !

Pour réduire les risques de décharges électriques, ne pas utiliser l'appareil en extérieur ou sur des surfaces humides.

- * Cet appareil n'est pas un jouet. Rester attentif quand il est utilisé par ou près des enfants.
- * Utiliser l'appareil conformément aux instructions de la notice. Utiliser seulement les accessoires préconisés par le fabricant.
- * Ne pas utiliser l'appareil si le câble d'alimentation ou la prise est endommagé. Retourner l'appareil au centre de service après-vente s'il ne fonctionne pas correctement, s'il est tombé, s'il a été endommagé, s'il a été laissé à l'extérieur ou s'il est tombé dans l'eau.
- * Ne pas tirer ou porter l'appareil par le câble d'alimentation, ou coincer le câble dans une porte ou tirer le câble sur des angles vifs ou des coins. Ne pas faire passer l'appareil sur le câble. Eloigner le câble des surfaces chaudes.
- * Ne pas débrancher l'appareil en tirant sur le câble d'alimentation, mais en saisissant la prise.
- * Ne pas manipuler la prise, le câble d'alimentation ou l'appareil avec les mains humides.
- * Ne rien introduire dans les ouvertures de l'appareil. Ne pas utiliser l'appareil si l'une des ouvertures est obstruée; éliminer la poussière, les peluches, les cheveux et tout corps étranger pouvant gêner le flux d'air.
- * Eloigner les vêtements amples, cheveux, doigts et toute autre partie du corps des pièces en mouvement et des ouvertures.
- * Ne pas aspirer d'objets qui brûlent ou dégagent de la fumée, comme des cigarettes, des allumettes ou des cendres chaudes, ni de poussières dangereuses pour la santé. Ne pas aspirer d'eau ou des liquides.
- * Ne pas utiliser sans sac à poussière et/ou filtre en place.
- * Placer toutes les commandes en position d'arrêt avant de débrancher l'appareil.
- * Eviter d'aspirer des corps durs ou pointus.
- * Etre particulièrement prudent en nettoyant les escaliers.
- * Ne pas aspirer de liquides inflammables ou combustibles, telle l'essence, et ne pas utiliser à proximité.
- * Eviter d'aspirer des objets durs ou pointus.
- * Ne pas modifier les systèmes électriques, mécaniques ou thermiques.
- * Remplacer le câble par un câble identique fourni par Advance.

CONSERVER CES INSTRUCTIONS

INSTRUCCIONES IMPORTANTES DE SEGURIDAD

Deben aplicarse ciertas precauciones básicas siempre que se utilice un aparato eléctrico, incluyendo las siguientes:
Lea todas las instrucciones antes de utilizar la máquina.

Esta máquina también es adecuada para el uso profesional, por ejemplo, en hoteles, colegios, hospitales, fábricas, tiendas y oficinas, que no sean los usos domésticos normales.

¡ESTE APARATO HA SIDO DISEÑADO ÚNICAMENTE PARA SU USO EN SECO!

¡NO UTILICE LA MÁQUINA EN SUELOS O MOQUETAS HÚMEDOS!

¡AVISO !

Para reducir el riesgo de incendio, descarga eléctrica o lesión:

- * No deje la máquina conectada a la red. Desenchufe la máquina cuando no se está utilizando y antes de efectuar una revisión.

¡AVISO !

Para reducir el riesgo de una descarga eléctrica, no utilice la máquina al aire libre, ni en superficies húmedas o mojadas.

- * No deje que se utilice la máquina como juguete. Debe prestarse una atención especial cuando la maneja o se utiliza cerca de los niños.
- * Siga escrupulosamente las indicaciones de este manual. Utilice únicamente piezas recomendadas por el fabricante.
- * No utilice la máquina con el cable o clavija en estado defectuoso. Si el aparato no funciona correctamente, si ha sufrido una caída o daños, si se ha dejado a la intemperie, o si ha sufrido una inmersión en agua, devuélvalo a un Centro de Servicio. No utilice la máquina si el cable eléctrico muestra cualquier signo de daño. Inspeccione regularmente el cable por si presente algún daño, especialmente cuando haya sido aplastado, cogido por una puerta o pisado por un objeto pesado.
- * No arrastre o transporte la máquina por el cable. No utilice el cable para dirigir la máquina. Mantenga el cable alejado de bordes y esquinas que lo podrían dañar. Así mismo, mantenga el cable alejado de fuentes de calor.
- * No desenchufe la máquina tirando del cable. Para desenchufar, tire de la clavija, no del cable.
- * No toque la clavija, el cable o la máquina con las manos húmedas o mojadas.
- * No inserte ningún objeto en las aberturas. No utilice la máquina con ninguna abertura obstruida.
- * Mantenga alejado de las aberturas y piezas en movimiento las prendas sueltas, el pelo, los dedos y todas las demás partes del cuerpo.
- * No aspire ningún tipo de objeto que esté ardiendo o que desprenda humo, como cigarrillos o cerillas. Bajo ninguna circunstancia la máquina podrá ser usada para aspirar materiales calientes. En particular no utilice la máquina para limpiar chimeneas, hornos o similares con cenizas calientes o incandescentes.
- * No utilice la máquina sin tener colocados los filtros y/o la bolsa del polvo.
- * Apague todos los controles antes de desenchufar la máquina. La clavija siempre debe ser desenchufada de la red eléctrica antes de revisar o reparar la máquina o el cable de conexión eléctrica.
- * No aspire objetos duros o afilados.
- * Tenga un cuidado especial cuando aspirar las escaleras.
- * No utilice la máquina para recoger combustible, materiales nocivos para la salud o materiales explosivos como la gasolina, tampoco debe utilizarse en atmósferas explosivas. No utilice la máquina para aspirar agua u otros líquidos o para aspirar polvo peligroso, contaminante o tóxico.
- * No realice ningún tipo de intervención o modificación en los dispositivos mecánicos, eléctricos o de seguridad térmica de la máquina.
- * Cuando repare o sustituya el cable de conexión eléctrica, utilice el mismo tipo de cable suministrado originalmente con la máquina. Este cable le puede ser suministrado por ADVANCE.

NO PIERDA ESTAS INSTRUCCIONES

GROUNDING INSTRUCTIONS

This appliance must be grounded. If it should electrically malfunction, grounding provides a path of least resistance for electric current to reduce the risk of electric shock. This appliance is equipped with a cord having an equipment-grounding conductor and grounding plug. The plug must be plugged into an appropriate outlet that is properly installed and grounded in accordance with all local codes and ordinances.

⚠ DANGER!

Improper connection of the equipment-grounding conductor can result in a risk of electric shock. Check with a qualified electrician or service person if you are in doubt as to whether the outlet is properly grounded. Do not modify the plug provided with the appliance. If it will not fit the outlet, have a proper outlet installed by a qualified electrician.

This appliance is for use on a nominal 120-volt circuit, and has a grounding plug that looks like the plug illustrated in Figure 1 below. A temporary adapter illustrated in Figures 2 and 3 may be used to connect this plug to a 2-pole receptacle as shown in Figure 2 if a properly grounded outlet is not available. The temporary adapter should be used only until a properly grounded outlet (Figure 1) can be installed by a qualified electrician. The green-colored rigid ear, tab, or the like extending from the adapter must be connected to a permanent ground such as a properly grounded outlet box cover. Whenever the adapter is used, it must be held in place by a metal screw. Grounding adapters are not approved for use in Canada. Replace the plug if the grounding pin is damaged or broken.

The Green (or Green/Yellow) wire in the cord is the grounding wire. When replacing a plug, this wire must be attached to the grounding pin only. Extension cords connected to this machine should be 12 gauge, three-wire cords with three-prong plugs and outlets. DO NOT use extension cords more than 50 feet (15 m) long.

PLEASE NOTE: FOR NORTH AMERICA ONLY

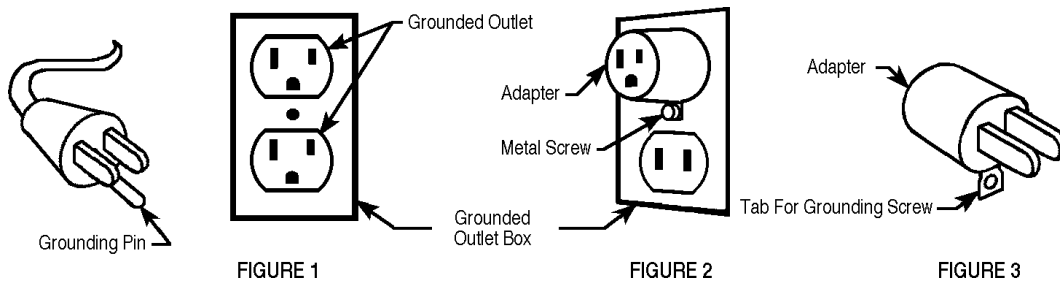

INSTRUCTIONS VISANT LA MISE À LA TERRE

Cet appareil doit être mis à la terre. En cas de défaillance ou de panne éventuelles, la mise à la terre fournit au courant un chemin de moindre résistance qui réduit le risque de choc électrique. Cet appareil est pourvu d'un cordon muni d'un conducteur de terre et d'une fiche avec broche de terre. La fiche doit être branchée dans une prise appropriée correctement installée et mise à la terre conformément aux règlements et ordonnances municipaux.

⚠ AVERTISSEMENT !

Un conducteur de terre mal raccordé peut entraîner un risque de choc électrique. Consulter un électricien ou un technicien d'entretien qualifié si vous n'êtes pas certain que la prise est correctement mise à la terre. Ne pas modifier la fiche fournie avec l'appareil - si elle ne peut être insérée dans la prise, faire installer une prise adéquate par un électricien qualifié.

Cet appareil est destiné à un circuit de 120 V et est muni d'une fiche de terre semblable à celle illustrée par le croquis 1. Un adaptateur temporaire semblable à celui illustré par le croquis 2 et C peut être utilisé pour brancher cette fiche à une prise bipolaire comme l'illustre le croquis 2 si une prise avec mise à la terre n'est pas disponible. L'adaptateur temporaire devrait être utilisé seulement jusqu'à ce qu'une prise avec mise à la terre soit installée par un électricien qualifié. L'oreille rigide ou le crochet ou autre dispositif semblable, de couleur verte, prolongeant l'adaptateur doit être raccordé à un élément correctement mis à la terre comme le couvercle d'une boîte de sortie mise à la terre. L'adaptateur doit être fixé par une vis métallique. **Note:** Au Canada, l'utilisation d'un adaptateur temporaire n'est pas autorisée par le Code canadien de l'électricité.

Remplacez la prise si la prise de terre est abîmée ou cassée.

Le fil Vert (ou Vert/Jaune) dans la gaine est le fil de terre. Lors du remplacement d'une prise, ce fil doit être raccordé à la prise de terre uniquement. Les rallonges connectées à cette machine doivent avoir 12 mesures, trois ganses de fil ayant **trois fiches masculines féminines tree-prong plugs and outlets**. N'UTILISEZ PAS de rallonge de plus de 15 m (50 pieds) de long.

VEUILLEZ NOTER: CES INSTRUCTIONS CONCERNENT UNIQUEMENT L'AMÉRIQUE DU NORD

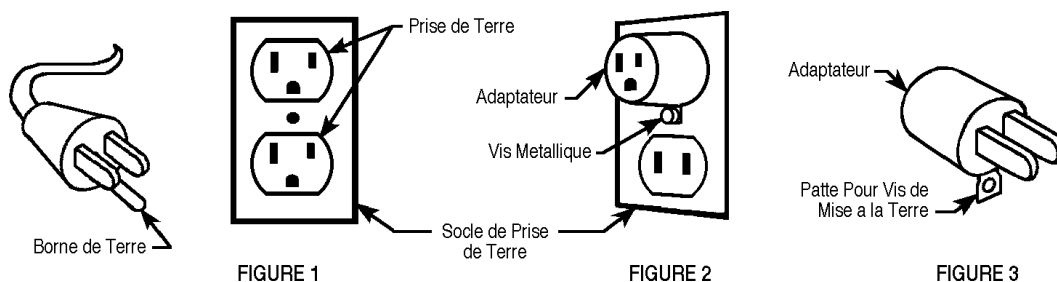

INTRUCCIONES PARA HACER LA TOMA A TIERRA

Este aparato deberá ser conectado a tierra. En caso de malfuncionamiento o de desperfectos, la toma a tierra proporciona una vía de menor resistencia de la corriente eléctrica para reducir el riesgo de choques eléctricos. Esta unidad viene equipada con un cordón con conductores para toma a tierra y con un enchufe con toma a tierra. Ese enchufe deberá ser enchufado a un receptáculo en buen estado con instalación a tierra según los códigos y ordenanzas de la zona.

⚠ ¡PELIGRO !

Si el conductor a tierra no está instalado correctamente pueden producirse riegos de choques eléctricos. En caso de duda, consulte con un electricista o personal de servicio autorizados. No modifique el cordón provisto con el aparato. Si no calza en el receptáculo, llame a un electricista calificado para que coloque un receptáculo adecuado.

Este aparato se usa con un circuito de 120-voltios nominales, y tiene un enchufe con toma a tierra tal como se muestra en la figura 1, a continuación. Se puede usar un adaptador provisorio tal como se ve en las figuras 2 y 3 en caso de disponerse de un receptáculo sin toma a tierra como en la figura 2. Dicho adaptador provisorio se usará solamente hasta que un electricista calificado instale un receptáculo con la toma a tierra correspondiente (figura 1). La lengüeta de conexión de color verde que sale del adaptador deberá ser conectada a una toma a tierra permanente como, por ejemplo, la caja del receptáculo con toma a tierra. Siempre que se use el adaptador, hay que sostenerlo en su lugar con un tornillo de metal.

Sustituya el enchufe si la patilla de tierra está dañada o rota.

El hilo verde (o verde/amarillo) del cordón es el hilo de tierra. Cuando sustituya el enchufe, este hilo sólo debe ir conectado a la patilla de tierra. Los cables alargadores conectados a esta máquina deben ser del calibre 12, trifilares, con tres patillas y tomas de pared adecuadas. NO UTILICE cables alargadores de más de 15 m.

ATENCIÓN : PARA AMÉRICA DE NORTE SOLAMENTE.

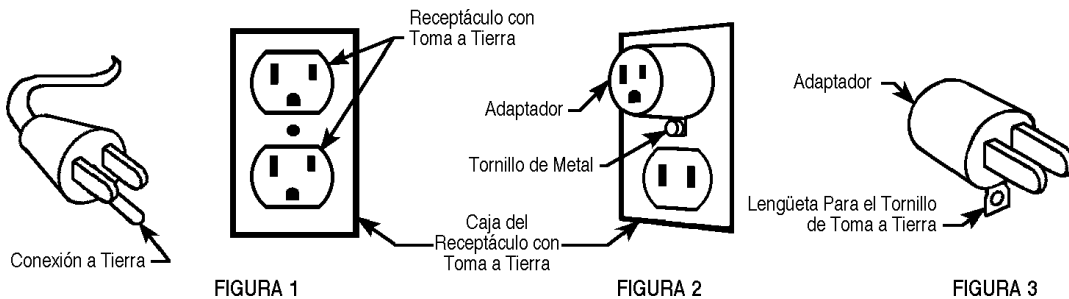

INTRODUCTION

This manual will help you get the most from your **Advance Carpetwin**. Read it thoroughly before operating the machine.

Note: Bold numbers in parentheses indicate an item illustrated on page 1.

This product is intended for commercial use only.

PARTS AND SERVICE

Repairs, when required, should be performed by your Authorized Advance Service Center, who employs factory trained service personnel, and maintains an inventory of Advance original replacement parts and accessories.

Call the ADVANCE DEALER named below for repair parts or service. Please specify the Model and Serial Number when discussing your machine.

(Dealer, affix service sticker here.)

NAME PLATE

The Model Number and Serial Number of your machine are shown on the Nameplate on the machine. This information is needed when ordering repair parts for the machine. Use the space below to note the Model Number and Serial Number of your machine for future reference.

MODEL NUMBER _____

SERIAL NUMBER _____

UNCRATE THE MACHINE

When the machine is delivered, carefully inspect the shipping carton and the machine for damage. If damage is evident, save the shipping carton so that it can be inspected. Contact the Advance Customer Service Department immediately to file a freight damage claim.

A-KNOW YOUR MACHINE

As you read this manual, you will occasionally run across a bold number in parentheses - example: **(2)**. These numbers refer to an item shown on this page. Refer back to this page whenever necessary, to pinpoint the location of an item mentioned in the text.

- 1 **Handle**
- 2 **Cord Hook**
- 3 **Vacuum Hose**
- 4 **Handle Lock Button**
- 5 **Bag Housing**
- 6 **Carrying Handle**
- 7 **Red Light**
- 8 **Green Light**
- 9 **Brush Housing**
- 10 **Brush Height Adjustment Knob**
- 11 **Pedal**
- 12 **Power Cord**
- 13 **Wand**
- 14 **Crevice Tool**
- 15 **"Bag Full" Light**
- 16 **Bag Housing Latch**
- 17 **Main Power Switch**
- 18 **Exhaust Filter Cover**
- 19 **Filter Cover Latch**
- 20 **Power Cord Clamp (Figure B)**
- 21 **Locking Latch (Figure B)**
- 22 **Dusting Brush**

B-SET UP AND ASSEMBLY

- 1 Carefully remove the machine from its carton.
- 2 Push the Handle **(1)** into the opening at the top of the Bag Housing **(5)** until the button snaps into the hole between the Switch **(17)** and the Bag Full Light **(15)**.
- 3 Install the Bag Housing **(5)** on the Brush Housing **(9)**. Slide the Locking Latch **(21)** to the left.
- 4 Measure 15 inches of Power Cord **(12)** from where it comes out of the machine. Insert the cord at this point into the Power Cord Clamp **(20)**.
- 5 Insert one end of the Vacuum Hose **(3)** into the top of the vacuum body and the other end into the extension wand. Insert the wand into the hole on the right side of the vacuum body and clip onto the right side of the machine. Snap the Hose **(3)** into the clip below the Handle **(1)**.
- 6 To install a Paper Dust Bag, push the Bag Housing Latch **(16)** and remove the back cover. Then follow the instructions printed on the Paper Dust Bag. **Never** operate the machine without a Dust Bag in place.

OPERATING THE MACHINE

- 1 To release the Power Cord (12) from the Cord Hooks (2), press the Handle Lock Button (4) in while pushing down on the Handle (1) and pull the power cord off the hooks. Plug the Power Cord into a properly grounded electrical outlet.
- 2 Turn the Main Power Switch (17) ON. "I" is ON and "O" is OFF.
- 3 Step on the Pedal (11) and tilt the handle back. The Green Light (8) on the base will come on to indicate that the brush motor is running.

C - IMPORTANT !

Foot pedal must be used to release base to operating position. Failure to do so could result in damage to the handle release mechanism.

- 4 Turn the Height Adjustment Knob (10) to adjust the height of the brush. If the Red Light (7) comes on, slowly turn the Knob in the opposite direction until the light goes off.

If the red light stays on continuously, there may be debris wrapped around the brush. This can cause the overload protector for the brush motor to trip. If this occurs, turn the Main Switch OFF and unplug the power cord. Remove any debris from the brush and turn the Main Switch back ON. This will automatically reset the overload protector. The machine can also be reset by locking the handle in the upright position. Remove any debris from the brush and repeat Step 3. If the overload protector trips repeatedly, or if the red light stays on continuously, contact Advance for service.

- 5 Change the bag whenever the "Bag Full" Light (15) comes on. If the light comes on before the bag is full, the inside of the bag may be coated with very fine dust (change the bag), or debris may be built up somewhere between the brush and the bag.

USING THE WAND

To use the Wand (13), put the Handle in the upright locked position. The brush motor will stop automatically. Slide the Wand out of its holder. Install the Crevice Tool (14) or Dusting Brush (22) on the end of the Wand, if desired.

AFTER USING THE MACHINE

- 1 Unplug the Power Cord from the electrical outlet and wrap it around the Cord Hooks on the front of the machine.
- 2 Check to see if the bag is full, replace if necessary. Clean the bag housing, if necessary.
- 3 Clean or replace the Vacuum Inlet Filter every third time the bag is changed. Clean or replace the Electrostat Exhaust Filter every fifth time the bag is changed.
- 4 Remove any built-up carpet fibers or debris from the brush housing.
- 5 Store the machine indoors in a clean, dry place.

VACUUM MOTOR BRUSHES

Have your Advance Dealer check the carbon motor brushes once a year or after 500 operating hours.

IMPORTANT !

Motor damage resulting from failure to service the carbon brushes is not covered under warranty. See the Limited Warranty Statement.

MAINTENANCE

CAUTION !

Always disconnect the Power Cord before performing any machine maintenance.

CHANGING THE PAPER DUST BAG

Change the Bag whenever the "Bag Full" Light comes on. To replace the Paper Dust Bag :

- 1 Push the Bag Housing Latch (16) in and remove the back cover.
- 2 Remove the Paper Dust Bag following the instructions printed on the bag.
- 3 Install a new Paper Dust Bag following the instructions printed on the bag.

IMPORTANT !

Never operate the machine without a Dust Bag in place.

CHANGING THE CLOTH DUST BAG

Empty the Bag whenever the "Bag Full" Light comes on. To empty the Cloth Dust Bag :

- 1 Push the Bag Housing Latch (16) in and remove the back cover.
- 2 Remove the Cloth Dust Bag following the instructions printed on the bag.
- 3 Remove bag clip and shake out bag contents.
- 4 Put the bag clip back on the bag.
- 5 Install the Cloth Dust Bag following the instructions printed on the bag.
- 6 Replace the Electrostat Exhaust Filter every fifth time the bag is changed (more often in very dusty applications).

IMPORTANT !

Never operate the machine without a Dust Bag in place.

CLEANING THE VACUUM INLET FILTER

The vacuum inlet filter catches any dirt spilled from the bag, before it can enter the vacuum motor. The filter is located just below the bag. Clean the filter every third time that the bag is changed (more often in very dusty applications). To clean the Vacuum Inlet Filter...

- 1 Push the Bag Housing Latch (16) in and remove the back cover.
- 2 Slide the Filter Holder out of the bottom of the Bag Housing.
- 3 Remove the filter and wash it in warm water. Let the filter dry completely before putting it back into the machine.

IMPORTANT !

Never operate the machine without the Vacuum Inlet Filter in place.

D-CHANGING THE ELECTROSTAT EXHAUST FILTER

The electrostat exhaust filter catches any dirt that may escape from the dust bag, vacuum inlet filter, or lower motor filter. The electrostat exhaust filter is located just below the carrying handle. **Replace the filter every fifth time that the dust bag is changed (more often in very dusty applications).**

To replace the Electrostat Exhaust Filter...

- 1 Push the Filter Cover Latch (19) in and remove the Electrostat Exhaust Filter Cover (18).
- 2 Remove the Filter from the filter holder and insert a new filter in its place.
- 3 Snap the Filter Cover back into place.

IMPORTANT !

Never operate the machine without the Electrostat Exhaust Filter in place.

CHANGING THE BRUSH

- 1 Lay the machine over onto its left side.
- 2 Slide the side cover (item #46 / page 13) off of the brush housing.
- 3 Carefully pry the roller support (item #40 / page 13) off the end of the brush (reuse on new brush).
- 4 Grasp the center of the brush by the bristles and pull it up and out the right side of the housing.
- 5 Slide brush end with hex opening into housing first, make sure it slides all the way down onto transmission support (item #34 / page 13).
- 6 Follow steps 1-3 in reverse order to reassemble.



REPLACING THE BELT

WARNING !

To reduce the risk of electric shock, unplug before servicing.

- 1 Remove screws (7 on Carpetwin 14 / 9 on Carpetwin 18) from the top cover (item #2 / page 13) and remove top cover from the brush housing.
- 2 Remove both screws in transmission support (item #34 / page 13).
- 3 Lift the end of the brush up and remove the belt from the brush pulley.
- 4 Bend brush housing out just enough to slide the belt off of the motor pulley (**be careful not to break housing!**).
- 5 Reassemble in reverse order.

TECHNICAL SPECIFICATIONS (as installed and tested on the unit)

Model		Carpetwin 14	Carpetwin 18
Voltage	V/Hz	120/60	120/60
Rated Power	W	900	920
Protection Class (electrical)			
Sound Pressure Level	dB(A)/20μPa	69	69
Total Weight	lbs / kg	19.5 / 8.8	20.5 / 9.3
Vibrations at the Hand Controls	m/s ²	<2.5m/s ²	<2.5m/s ²

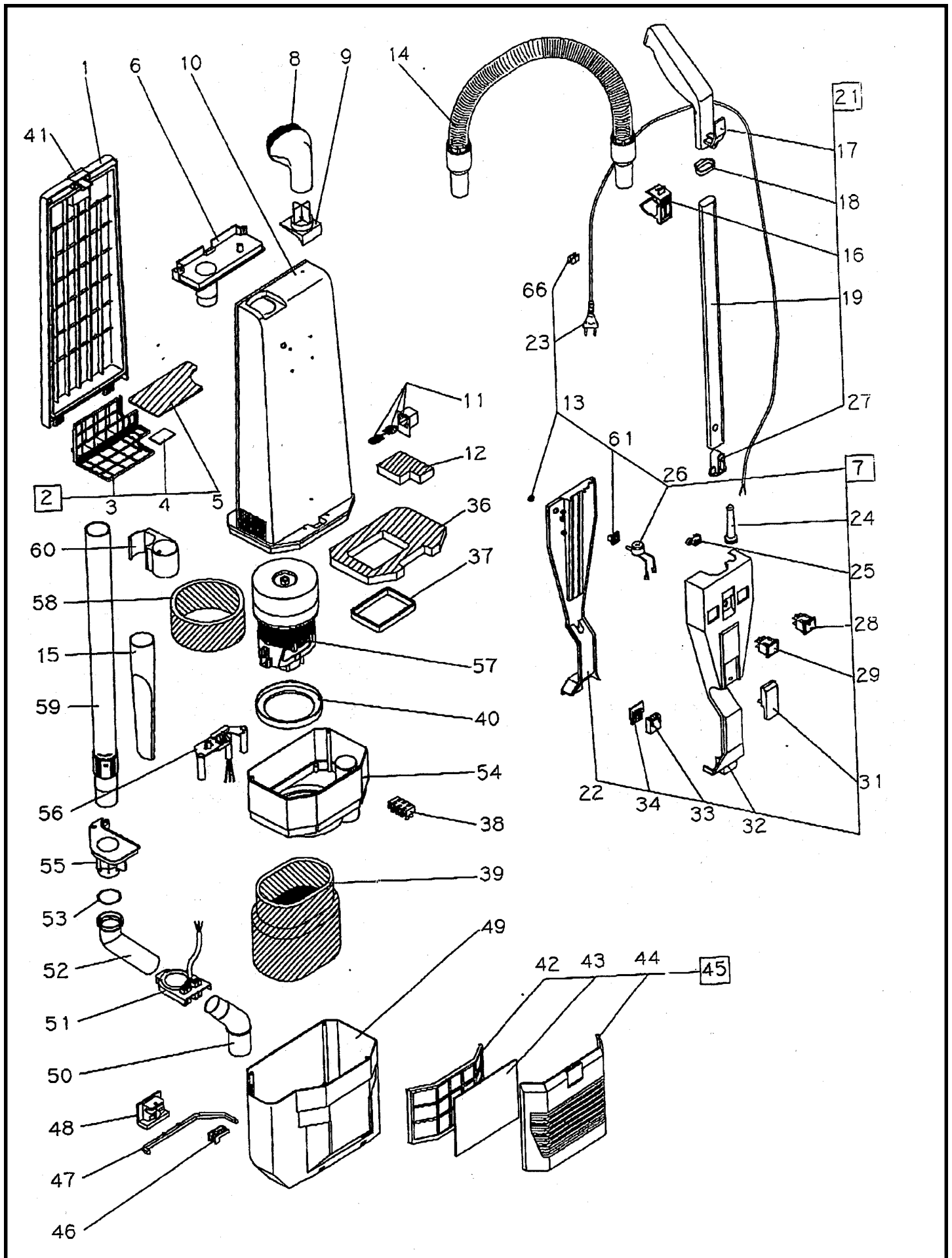

BAG HOUSING

Item	Ref. No.	Qty	Description	Item	Ref. No.	Qty	Description
1	56704205	1	Bag Housing Cover	41	56704212	1	Bag Door Latch (w/spring)
2	56646851	1	Grill Complete	42	56704222	1	Filter Holder
3	56703712	1	Grill Filter Holder	43	56646888	1	Exhaust Filter (pkg of 5)
4	56703714	1	Scented Pad (pkg of 10)	44	56704223	1	Exhaust Filter Cover
5	56703713	1	Internal Filter	45	56704224	1	Complete Grill
6	56703720	1	Bag Entrance	46	56703966	1	Blocking Joint Pin
7	56704206	1	Electrical System Assembly (3 wires)	47	56703938	1	Joint Pin
8	56703785	1	Round Dusting Brush	48	56646893	1	Control Pin Slide
9	56646858	1	Round Dusting Brush Support	49	56704225	1	Vacuum Motor Housing
10	56704207	1	Bag Housing	50	56646895	1	Lower Curve
11	56703779	1	Valve Kit	51	56646896	1	Curve Support
12	56646861	1	Valve Filter	52	56646897	1	Upper Curve
13	56703978	1	O-Ring	53	56646898	1	O-Ring
14	56704216	1	SemiFlex Hose W/Sleeves	54	56704215	1	Inner Vacuum Motor Housing
15	56703725	1	Crevice Tool	55	56646900	1	Hose Inlet
16	56704208	1	Upper Hook for Flex Tube	56	56646901	1	Cord Clamp
17	56646865	1	Handle Grip	57	56704237	1	Vacuum Motor NOTE 1
18	56704209	1	Retainer	*	56704238	2	Carbon Brush for 56704237 & 56704168
19	56704221	1	Chromate Tube				TSBUS2002-829
21	56646869	1	Handle Tube Assy	58	56703775	1	Foam Filter
22	56704210	1	Handle Cover	59	56704213	1	Telescopic Wand
23	56703795	1	Cord, 3 x 18	60	56704214	1	Wand Clip
24	56703662	1	Strain Relief	61	56704226	1	Vacuum Sensor Adapter
25	56703977	1	Cord Clamp	66	56703990	1	Cord Clip
26	56704159	1	Vacuum Sensor				
27	56646875	1	Button (w/support & spring)				
28	56703708	1	Main Switch	**	56703768	A/R	Bag, Paper (pkg of 10)
29	56646877	1	Indicator Light	**	56703769	A/R	Cloth Bag W/Clip
31	56646878	1	Cord Hook	**	56320676	A/R	Clip, Cloth Bag
32	56704211	1	Frame Handle Assy	**	56703774	A/R	Upholstery Tool
33	56646879	1	Contact Housing	**	56703771	A/R	Extension Tube, 30mm x 30cm
34	56646880	1	Contact Cover	**	56703772	A/R	Tube Bend W/Suction Control
36	56703706	1	Foam Filter				
37	56703705	1	Gasket	** = Optional			
38	56703972	1	Terminal Block	* = Not Shown			
39	56646884	1	Foam Motor Filter				
40	56646885	1	Gasket				

NOTE 1: 56704168 used prior to SN1498331 on 14" & prior to SN1499231 on 18"

BRUSH HOUSING - 14 / 18

Item	Ref. No.	Qty	Description	Item	Ref. No.	Qty	Description
	56704203	1	Brush Housing Assembly, 14"	31	56703853	1	Pulley Nut
	56704204	1	Brush Housing Assembly, 18"	32	56704042	1	Circuit Board
1	56704227	1	Body Main Brush Head, 14"	33	56704155	1	Channel Cover
	56704228	1	Body Main Brush Head, 18"	34	56704044	1	Transmission Support
2	56704229	1	Electric Brush Cover, 14"	35	56703747	1	Brush Pulley
	56704230	1	Electric Brush Cover, 18"	36	56703746	1	Brush Pulley Nut
3	56704148	1	Joint Complete w/pin slide (#4)	37	56704039	1	Timing Belt
4	56704016	1	Joint Pin Slide	38	56704047	1	Wheels Support
5	56704017	1	Support Right Joint w/felt seal	39	56704041	4	Screw, 3.9 x 16mm
6	56704018	2	Plunger	40	56704049	1	Roller Support
7	56703766	2	Spring, Handle Release Pedal	41	56704050	1	Side Lever
8	56704019	1	Double Pin Washer	42	56704051	1	Front Bumper Gasket, 14"
9	56704020	1	Double Release Plate		56704052	1	Front Bumper Gasket, 18"
10	56704107	1	Handle Release Pedal	43	56704053	1	Back Bumper Gasket, 14"
11	56704022	1	Support Left Joint w/felt seal		56704054	1	Back Bumper Gasket, 18"
12	56704023	1	Switch Activator Pin	44	56704055	5	Screw, 4.8 x 50mm (qty of 6 on 18")
13	56704024	1	Spring	45	56704056	2	Screw, 3.5 x 38mm (qty of 3 on 18")
14	56703738	1	Brush Motor Switch	46	56704105	1	Side Cover
15	56703762	1	Brush Adjuster	47	56704058	1	Brush Roller, 14"
16	56703008	1	Brush Adjuster Knob		56704059	1	Brush Roller, 18"
17	56704028	1	Front Axle	48	56704060	1	Brush Motor Filter
18	56703757	2	Front Wheel	49	56704046	5	Screw, 3.9 x 13mm
19	56704030	1	Spring, Brush Adjust	50	56704067	2	Screw, 3.5 x 22mm
20	56704031	1	Rear Axle	51	56704045	1	Screw, 2.2 x 16mm
21	56704032	2	Rear Wheel	52	56704217	1	Lens Set, Red / Green
22	56704033	2	Wheel Retainer	53	56704218	1	Felt for brush housing
23	56704065	4	Screw, 2.9 x 16mm	54	56704140	1	Shoe Kit, 14"
24	56704106	1	Filter Grill		56704141	1	Shoe Kit, 18"
25	56704035	1	Brush Motor Filter	55	56704135	1	O-Ring
26	56704124	1	Stop Grill Plate	56	56704131	1	Male Electrical Connection Set
27	56703743	1	Brush Motor, 14"	57	56704231	3	Washer
	56704037	1	Brush Motor, 18"				
*	56704137	2	Carbon Brush for 56703743 & 56704037				
28	56704038	1	Brush Motor Support Kit				
29	56704130	1	Pulley Spacer				
30	56704129	1	Pulley				

* = Not Shown

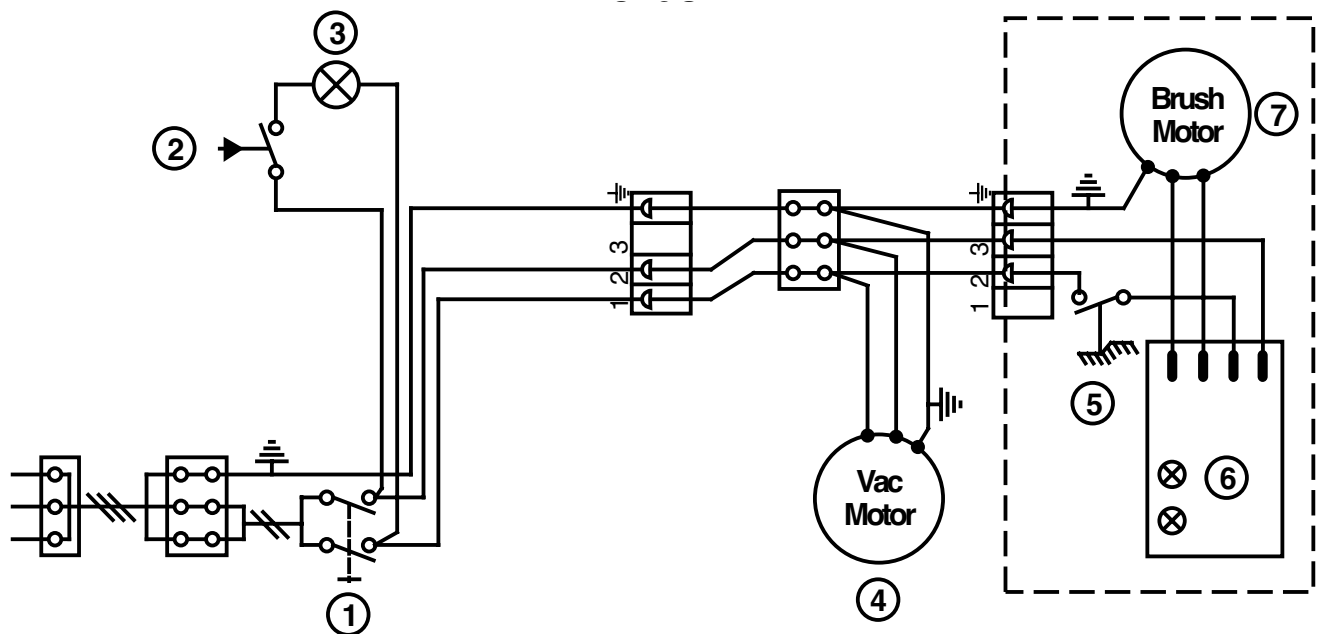

WIRING DIAGRAM

Item	Ref. No.	Qty	Description
1	56703708	1	Main Switch
2	56704159	1	Vacuum Sensor
3	56646877	1	Indicator Light
4	56704237	1	Vacuum Motor (56704168 used prior to SN1498331 on 14" & SN1499231 on 18")
*	56704238	2	Carbon Brush for 56704237 & 56704168 TSBUS2002-829
5	56703738	1	Brush Motor Switch
6	56704042	1	Circuit Board
7	56703743	1	Brush Motor, 14"
	56704037	1	Brush Motor, 18"
*	56704137	2	Carbon Brush for 56703743 & 56704037

Carpetwin 14 / 18 TWO YEAR LIMITED WARRANTY FOR MODELS 56704200 & 56704201 ONLY

Nilfisk-Advance, Inc. warrants each new Carpetwin 14 / 18 carpet vacuum against defects in material and workmanship under normal use and service. The obligation under this warranty is limited to repair or replace at our factory or authorized distributor service station any part or parts thereof which within the warranty period are returned to our factory or authorized distributor service station, transportation prepaid, after examination discloses it to have been thus defective.

The warranty period during which basic coverage applies is Two (2) years for parts replacement and one year for service labor. The start date of the warranty coverage shall be the purchase date by the original end user, or six months from the date the machine was shipped from the factory, whichever is earlier. The Warranty Registration Card is to be completed and returned immediately at the time of purchase.

This warranty shall not apply to: (1) accidents and misuse, (2) damage in transit, (3) overloading the capacity of the machine, (4) failure due to lack of proper maintenance or care as described in the operating and maintenance instructions, (5) relatively minor adjustments such as tightening of screws or bolts, etc., not connected with the replacement of parts, (6) repairs or alterations by an organization other than the factory or an authorized Nilfisk-Advance Service Center.

STATED WARRANTIES ARE IN LIEU OF ALL OTHER WARRANTIES, EXPRESSED OR IMPLIED. Any statutory implied warranties, including any warranty of merchantability or fitness for a particular purpose, are expressly limited to the durations of this written warranty. Nilfisk-Advance will not be liable for any other damages arising out of or in connection with the furnishing, performance, use of or inability to use the machine. This remedy shall be the exclusive remedy of the Buyer.

Authorized Nilfisk-Advance Service Centers can assist owners in the proper handling of any warranty question or claim. In the event that you want to contact Nilfisk-Advance directly, please write to the Customer Service Department at Nilfisk-Advance, Inc., 14600 21st Avenue North, Plymouth, Minnesota 55447-3408. Provide an explanation of the problem and include the serial number of the machine as well as the name of the selling organization. The Customer Service Department will investigate and then contact you.

Cut out and mail to:
Nilfisk-Advance, Inc.
14600 21st Avenue North
Plymouth, Minnesota 55447-3408

IMPORTANT: This card contains information necessary to expedite warranty protection.
Mail within 30 days of purchase to Nilfisk-Advance.

LIMITED WARRANTY
PLEASE PRINT

Purchaser _____
Address _____
City _____ **State** _____ **Zip** _____
Model _____ **Serial Number** _____
Purchased from _____
City _____ **State** _____ **Zip** _____
Date Purchased _____

**THIS IS TO CERTIFY THAT THE ABOVE EQUIPMENT
WAS CHECKED OUT IN WORKING CONDITION.**