



Electronic Service Manuals

This electronic document is provided as a service to our customers. We do not create the contents of the information contained in this document. Should you have detailed questions pertaining to the information contained in this document, you may contact Michco, or the manufacturer which provided the original information in this electronic deliverable. Michco's only part in this electronic deliverable was the electronic assembly process.

You may contact Michco through the following methods:
Phone (517) 484-9312 or (800) 331-3339 MI, OH, IN only
2011 N. High St. -- Lansing, Michigan -- 48906
Fax: (517) 484-9836
Email: CustServ@Michco.com
Web site: www.Michco.Com
Parts Web site: www.FloorMachineParts.Com

Order Parts on Line at:
www.FloorMachineParts.Com

Directly to Parts & Service:
By Email: **Shop@Michco.com**
By Fax: (517) 702-2041
By Voice: Use numbers above.

Serving the Cleaning Industry Since 1922

Notice: All copyrighted material remains property of original owners, all trademarks are property of respective owners. Manuals are subject to Manufacturer's reproduction limitations. Originals or reproductions were provided by manufacturers through a request. We make no warranty as to the correctness of information provided in this document and you assume all risk.

ADVANCE

OPERATOR M A N U A L

Hydro-Retriever™ 2067

Models 463684 (G), 463683 (P), 463685 (D)



TABLE OF CONTENTS

	page
Introduction	2
Parts and Service	2
Nameplate	2
Uncrating the Machine	3
Safety Instructions	4
General Information	5-6
 Know Your Machine	 7-10
 Preparing the Machine for Use	
Before Each Use	11
Main Broom	11
Scrub Brushes	11
Filling the Solution Tank	11
Fuel	12
 Operating the Machine	
Before Starting the Machine	13
Starting the Diesel Engine	13
Starting the Gasoline Engine	14
Starting the Propane Engine	14
Sweeping	15
Emptying the Hopper	15
Scrubbing	16
Emptying the Recovery Tank	16
 After Using the Machine	
After Each Use	17
Shutting Down the Diesel Engine	17
Shutting Down the Gasoline Engine	17
Shutting Down the Propane Engine	17
 Maintenance	
Every 15 Hours of Operation	18
Every 30 Hours of Operation	18
Every 100 Hours of Operation	18
Every 300 Hours of Operation	18
Every 1500 Hours of Operation	18
Main Broom Maintenance	19
Side Broom Maintenance	20
Squeegee Maintenance	21
Impeller Maintenance	22
Lubrication	22
Hydraulic Oil	23
Engine Oil	23
Engine Coolant	23
Engine Air Filter	24
Dust Control Filter	25
Fuse Location	25
 Specifications	 26

INTRODUCTION

This manual will help you get the most from your Advance Hydro-Retriever™ 2067. Read it thoroughly before operating the machine. References to “right” and “left” in this manual mean right or left as seen from the driver’s seat.

Note: Bold numbers in parentheses indicate an item illustrated on pages 7-8.

PARTS AND SERVICE

Repairs, when required, should be performed by your Authorized Advance Service Center, who employs factory trained service personnel, and maintains an inventory of Advance original replacement parts and accessories.

Call the ADVANCE INDUSTRIAL DEALER named below for repairs or service. Please specify the Model and Serial Number when discussing your machine.

(Dealer, affix service sticker here.)

NAMEPLATE

The Model Number and Serial Number of your machine are shown on the Nameplate, located on the wall of the operator’s compartment. This information is needed when ordering repair parts for the machine. Use the space below to note the Model Number and Serial Number of your machine for future reference.

MODEL _____

SERIAL NUMBER _____

MODEL NUMBER	ENGINE MAKE	ENGINE MODEL NUMBER	FUEL
463683	FORD	VSG 413I-6005-A	Propane
463684	FORD	VSG 413I-6005-A	Gasoline
463685	KUBOTA	V1903E-1	Diesel

Note: Reference the separately supplied engine manufacture’s maintenance and operator manual for more detailed engine specification and service data.

UN-CRATING

Upon delivery, carefully inspect the shipping crate and the machine for damage. If damage is evident, save all parts of the shipping crate so that they can be inspected by the trucking company that delivered the machine. Contact the trucking company immediately to file a freight damage claim.

- 1 After removing the crate, remove the wooden blocks next to the wheels.
- 2 Check the engine oil and coolant levels.
- 3 Check the hydraulic oil level.
- 4 Read the instructions in the Preparing the Machine For Use section of this manual, then fill the fuel tank.
- 6 Place a ramp next to the front end of the pallet.
- 7 Read the instructions in the Operating Controls and Operating the Machine sections of this manual and start the engine. Slowly drive the machine forward down the ramp to the floor. Keep your foot lightly on the brake pedal until the machine is off the pallet.

CAUTION!

Use extreme CAUTION when operating this machine. Be certain that you are thoroughly familiar with all operating instructions before using this machine. If you have any questions, contact your supervisor or your local Advance Industrial Dealer.

If the machine malfunctions, do not try to correct the problem unless your supervisor directs you to do so. Have a qualified company mechanic or an authorized Advance Dealer service person make any necessary corrections to the equipment.

Use extreme care when working on this machine. Loose clothing, long hair, and jewelry can get caught in moving parts. Turn the Key Ignition Switch OFF and remove the key before servicing the machine. Use good common sense, practice good safety habits and pay attention to the yellow decals on this machine.

CAUTIONS AND WARNINGS

SYMBOLS

Advance uses the symbols below to signal potentially dangerous conditions. Always read this information carefully and take the necessary steps to protect personnel and property.

DANGER !

Is used to warn of immediate hazards that will cause severe personal injury or death.

WARNING !

Is used to call attention to a situation that could cause severe personal injury.

CAUTION !

Is used to call attention to a situation that could cause minor personal injury or damage to the machine or other property.

GENERAL SAFETY INSTRUCTIONS

Specific Cautions and Warnings are included to warn you of potential danger of machine damage or bodily harm.

DANGER !

- * This machine emits exhaust gases (carbon monoxide) that can cause serious injury or death, always provide adequate ventilation when using machine.

WARNING !

- * This machine shall be used only by properly trained and authorized persons.
- * While on ramps or inclines, avoid sudden stops when loaded. Avoid abrupt sharp turns. Use low speed down hills. Clean only while ascending (driving up) the ramp.
- * To avoid hydraulic oil injection or injury always wear appropriate clothing and eye protection when working with or near hydraulic system.
- * Turn the key switch off (O) and disconnect the batteries before servicing electrical components.
- * Never work under a machine without safety blocks or stands to support the machine.
- * Do not dispense flammable cleaning agents, operate the machine on or near these agents, or operate in areas where flammable liquids exist.
- * Do not clean this machine with a pressure washer.

CAUTION !

- * This machine is not approved for use on public paths or roads.
- * This machine is not suitable for picking up hazardous dust.
- * Use care when using scarifier discs and grinding stones. Advance will not be held responsible for any damage to floor surfaces caused by scarifiers or grinding stones.
- * When operating this machine, ensure that third parties, particularly children, are not endangered.
- * Before performing any service function, carefully read all instructions pertaining to that function.
- * Do not leave the machine unattended without first turning the key switch off (O), removing the key and applying the parking brake.
- * Turn the key switch off (O) before changing the brushes, and before opening any access panels.
- * Take precautions to prevent hair, jewelry, or loose clothing from becoming caught in moving parts.
- * Use caution when moving this machine in below freezing temperature conditions. Any water in the solution or recovery tanks or in the hose lines could freeze.
- * Before use, all doors and hoods should be properly latched.

SAVE THESE INSTRUCTIONS

HOPPER SAFETY SUPPORT

⚠ WARNING!

Make sure the Hopper Safety Support (A) is in place whenever attempting to do any maintenance work under or near the raised hopper. The Hopper Safety Support (A) holds the hopper in the raised position to allow work to be performed under the hopper. NEVER rely on the machine's hydraulic components to safely support the hopper.

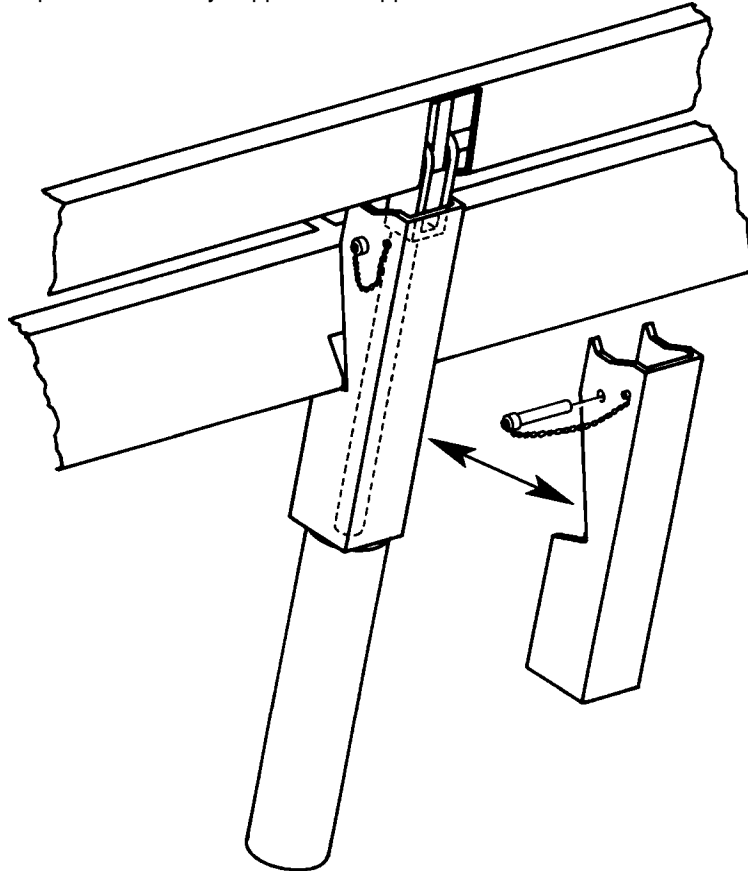

JACKING THE MACHINE

⚠ CAUTION!

Never work under a machine without safety stands or blocks to support the machine.

- When jacking the machine, do so at designated locations (Do Not jack on the hopper) - see jacking locations (8)

TRANSPORTING THE MACHINE

⚠ CAUTION!

Before transporting the machine on an open truck or trailer, make sure that . . .

- All access doors are latched securely.
- The machine is tied down securely - see tie-down locations (4 & 5).
- The machine parking brake is set.

GENERAL INFORMATION

TOWING OR PUSHING A DISABLED MACHINE

⚠ CAUTION!

The machine's drive propelling pump is manufactured with an adjustable tow valve. This valve prevents damage to the hydraulic system when the machine is being towed/pushed short distances without use of the engine.

To access the valve open the engine compartment cover and door. Locate the valve as shown on top rear of the propelling pump. Use a pliers or 5/16" (8 mm) open end wrench to turn the valve 90 degrees, this disengages the hydrostatic lock between the motor and pump.

The hydraulic propelling pump can be damaged if the machine is towed with the valve in the normal working position **(A)**. Reference the illustrations below for the normal working setting **(A)** (vertical) and the free wheeling towing setting **(B)** (horizontal). Note: If the tow valve is left in free wheeling **(B)** (horizontal) position the propelling pump can't drive the machine FWD or REV. No damage will result, just re-set valve to the normal working setting **(A)** (vertical). Tow or push machine no faster than a normal walking pace (2-3 miles per hour) and for short distances only. If the machine is to be moved long distances the rear drive wheels needs to be raised off the floor and placed on a suitable transport dolly.

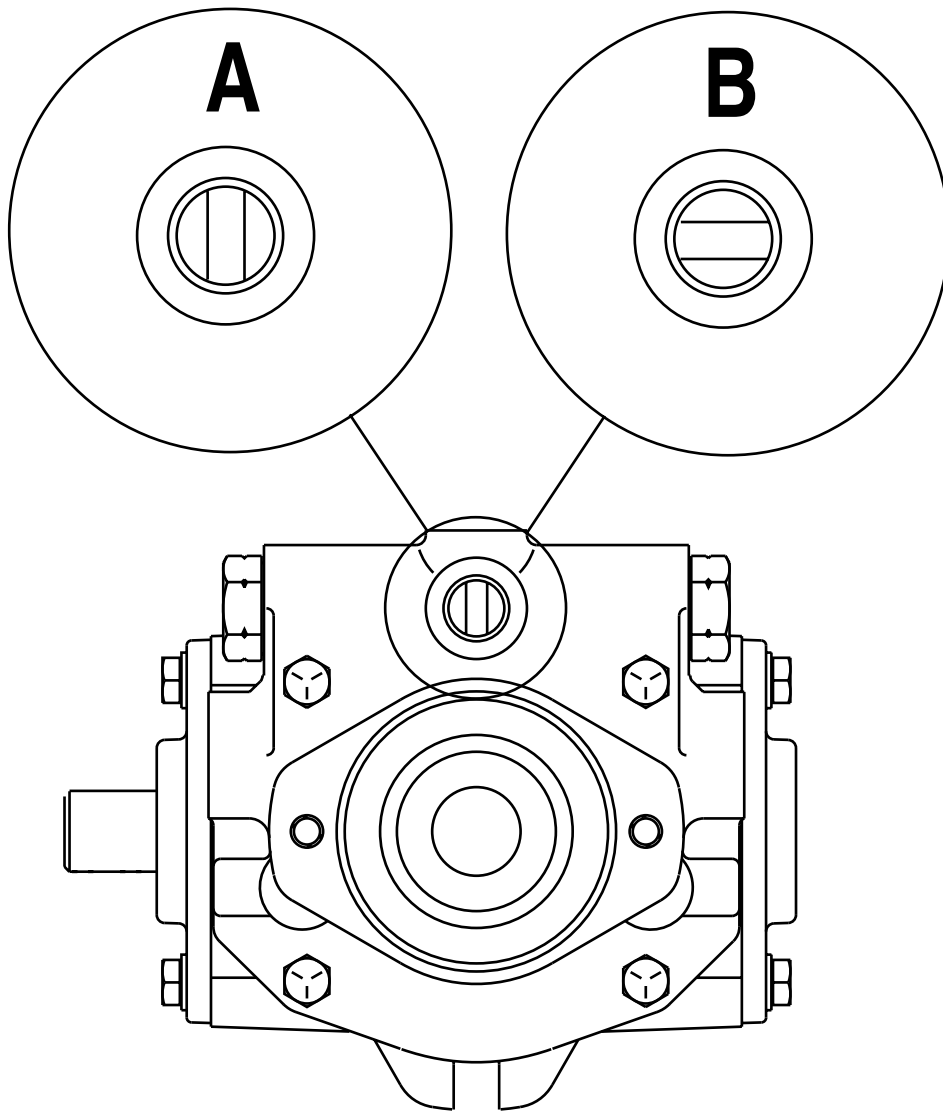

KNOW YOUR MACHINE

- 1 Recovery Tank Cover
- 2 Solution Tank Cover
- 3 Engine Access Door
- 4 Tie-down Location (2 tie-downs on back bumper)
- 5 Tie-down Location (one on each side)
- 6 Side Broom
- 7 Dust Control Filter Compartment
- 8 Jacking Points (under bumper when side doors are open)

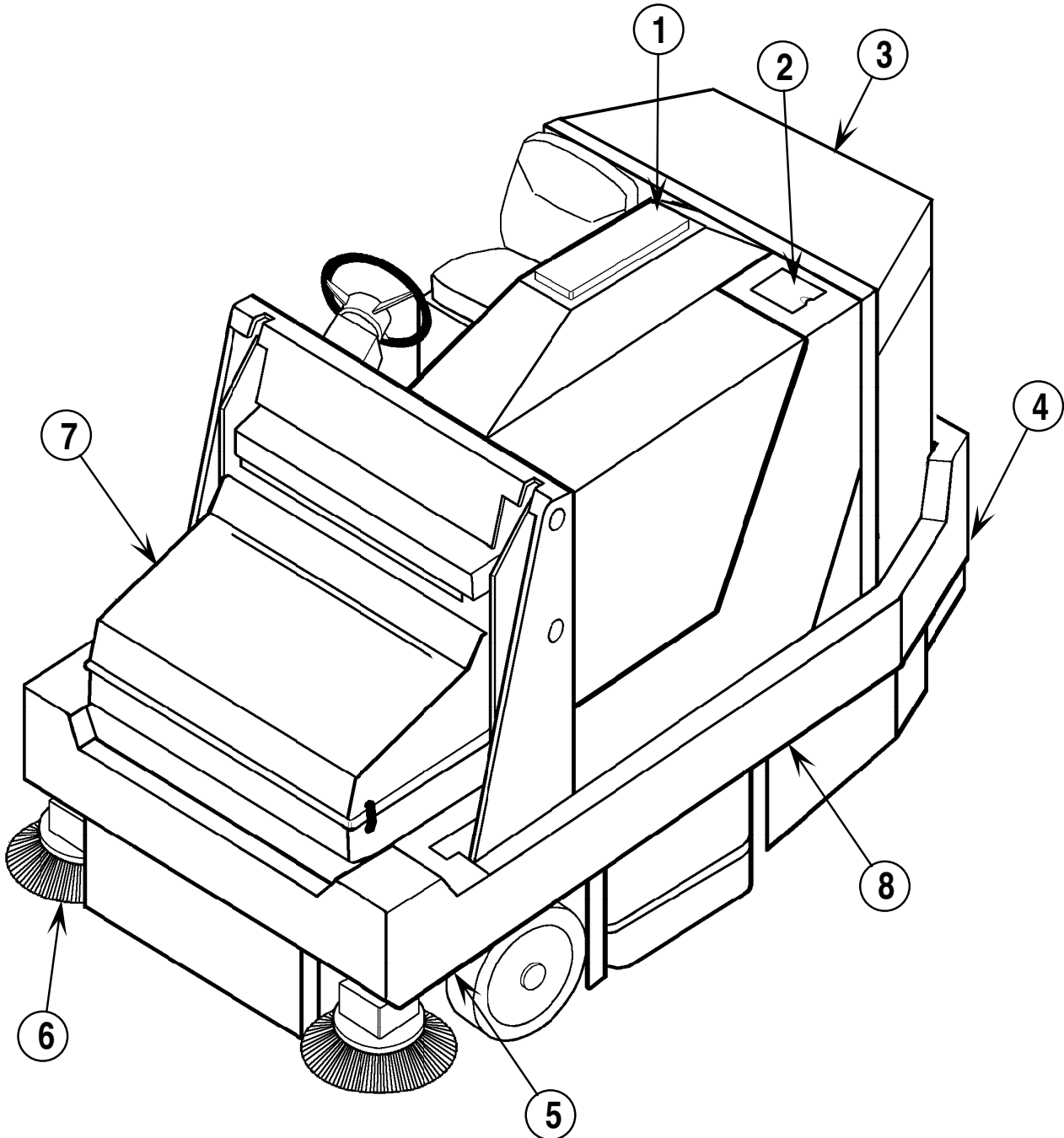

OPERATOR'S COMPARTMENT

- | | | | |
|----|---------------------------------|----|------------------------------------|
| 1 | Choke (Gasoline Engine Only) | 18 | Hopper Raise/Lower Switch |
| 2 | Dust Control Lever | 19 | Key Ignition Switch |
| 3 | Throttle Control Lever (Diesel) | 20 | Throttle Control Switch |
| 4 | Main Broom Lever | 21 | Brake Pedal |
| 5 | Hydraulic Filter Light | 22 | Horn Button |
| 6 | Hydraulic Oil Hot Light | 23 | Forward/Reverse Drive Pedal |
| 7 | Scrub Brushes On/Off Switch | 24 | Main Broom Adjustment Knob |
| 8 | Broom Motors On/Off Switch | 25 | Parking Brake Lever |
| 9 | Squeegee Raise/Lower Switch | 26 | Hydraulic Oil Tank |
| 10 | Side Broom Raise/Lower Switch | 27 | Tip-Forward Seat Compartment |
| 11 | Solution Control Lever | 28 | Side Broom Speed Lever |
| 12 | Fuel Gauge | 29 | Fuel Tank |
| 13 | Oil Pressure Gauge | 30 | Fuel Storage Access Door |
| 14 | Water Temperature Gauge | 31 | Glow Plug Indicator Light (Diesel) |
| 15 | Battery Meter | 32 | Head Light Switch |
| 16 | Hour Meter | | |
| 17 | Hopper Dump Door Switch | | |

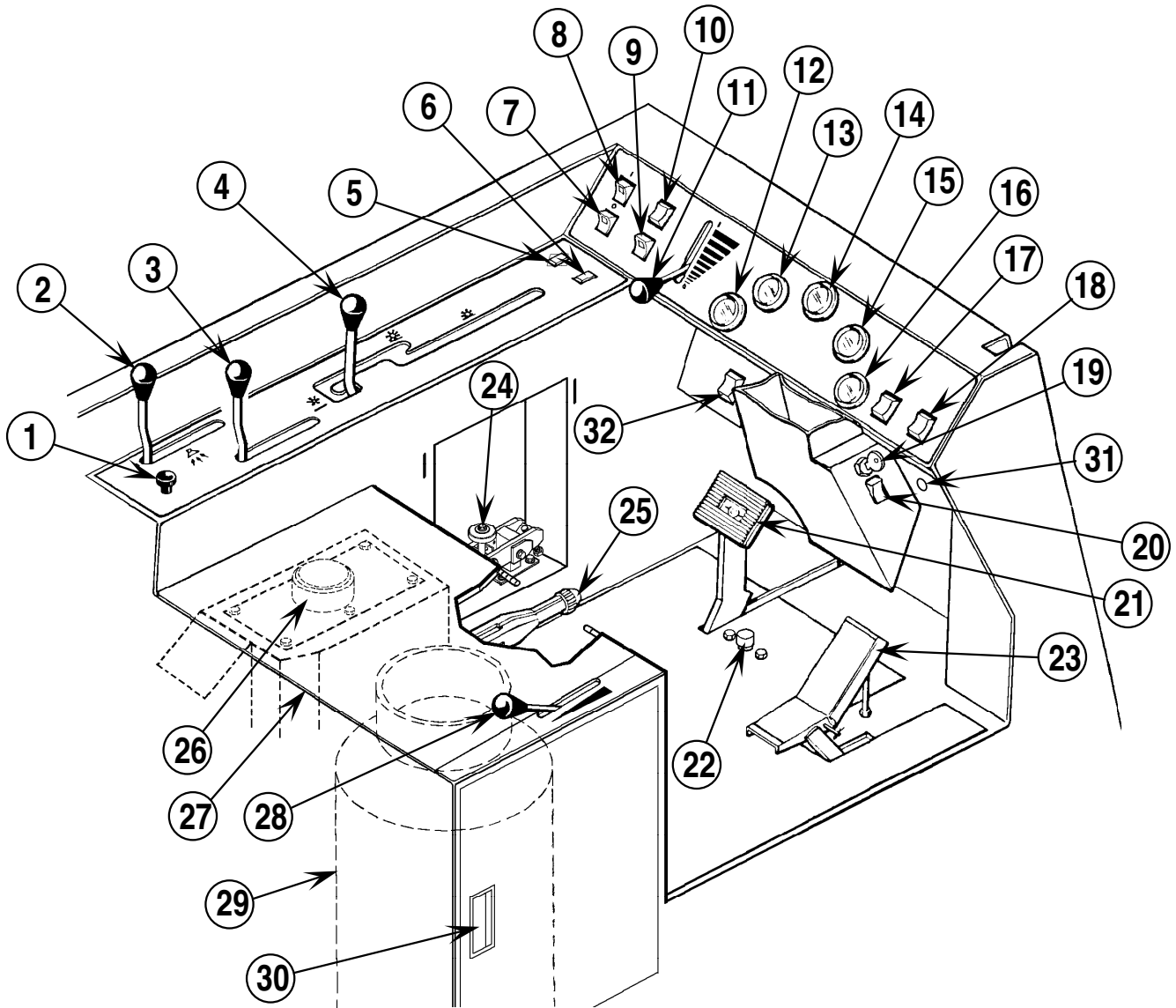

KNOW YOUR MACHINE

- 1 CHOKER - primes the gasoline engine for cold starting.
- 2 DUST CONTROL LEVER - controls the vacuum system and the vacuum filter shaker. The vacuum system picks up dust raised by the main broom. The filter shaker cleans the vacuum filter.
- 3 THROTTLE CONTROL LEVER (DIESEL) - controls the speed of the engine. When operating the machine, the throttle control lever should be in the full throttle position.
- 4 MAIN BROOM LEVER - raises and lowers the main sweeping broom. The sweep position is for smooth floors. The full float position is for rough floors.
- 5 HYDRAULIC FILTER LIGHT - indicates when the hydraulic oil filter should be serviced.
- 6 HYDRAULIC OIL HOT LIGHT - when this light glows, shut down the machine immediately. Allow the machine to cool down, then check for a problem in the hydraulic system.
- 7 SCRUB BRUSHES ON/OFF SWITCH - raises (and shuts off) the scrub brushes, or lowers (and starts) the scrub brushes.
- 8 BROOM MOTORS ON/OFF SWITCH - starts or stops the hydraulic motors that turn the main and side brooms.
- 9 SQUEEGEE RAISE/LOWER SWITCH - raises and lowers the squeegee. With the rocker switch on, the squeegee is in the automatic mode. Raising and lowering is controlled by the forward/reverse drive pedal. The squeegee will raise in reverse and lower in forward.
- 10 SIDE BROOM RAISE/LOWER SWITCH - raises or lowers the side broom.
- 11 SOLUTION CONTROL LEVER - controls the amount of solution dispensed to the scrub brushes.
- 12 FUEL GAUGE - indicates the amount of fuel in the gasoline or diesel fuel tank.
- 13 OIL PRESSURE GAUGE - indicates the engine oil pressure while the engine is running.
- 14 WATER TEMPERATURE GAUGE - indicates the temperature of the engine coolant while the engine is running.
- 15 BATTERY METER - indicates the level of battery charge.
- 16 HOUR METER - indicates the accumulated hours of usage.
- 17 HOPPER DUMP DOOR SWITCH - opens and closes the hopper dump door.
- 18 HOPPER RAISE/LOWER SWITCH - controls the hydraulic cylinder that raises the hopper for dumping.
- 19 KEY IGNITION SWITCH - controls the engine and some parts of the electrical system.
- 20 THROTTLE CONTROL SWITCH - controls the speed of the engine. When operating the machine, the throttle control switch should be in the full throttle position (III).

KNOW YOUR MACHINE

- 21 BRAKE PEDAL - operates the mechanical brakes on the front wheels.
- 22 HORN BUTTON - sounds the horn.
- 23 FORWARD/REVERSE DRIVE PEDAL - controls the machine's travel speed and direction:
Push down on the Back of the pedal to move the machine Backward.
Push down on the Front of the pedal to move the machine Forward.
The SPEED of the machine will increase as the pedal is pushed closer to the floor. Maximum forward speed is faster than maximum reverse speed.
- 24 MAIN BROOM ADJUSTMENT KNOB - adjusts the height of the main broom to compensate for bristle wear.
- 25 PARKING BRAKE LEVER - locks the mechanical parking brakes on the front wheels.
- 26 HYDRAULIC OIL TANK - holds the hydraulic system oil.
- 27 TIP-FORWARD SEAT COMPARTMENT - seat tips forward for access to the hydraulic oil tank. Engage prop bar for safety.
- 28 SIDE BROOM SPEED LEVER - controls the speed of the motor that turns the side broom.
- 29 GAS/DIESEL FUEL TANK - 12 gallon (45 liter) capacity
PROPANE FUEL TANK - 33 lb. liquid withdrawal propane tank.
- 30 FUEL STORAGE ACCESS DOOR - provides access for LP tank installation & gasoline/diesel tank filling.
- 31 GLOW PLUG INDICATOR LIGHT - turns red when the glow plugs are pre-heated for cold starts (Diesel).
- 32 HEADLIGHT SWITCH - turns on the headlights.

PREPARING THE MACHINE FOR USE

BEFORE EACH USE

- Inspect the machine for damage and oil or water leaks.
 - Check the engine oil level.
 - Check the fuel level.
 - Check to see that the hopper and the recovery tank are empty.
 - Squeeze the rubber dust cup on the engine air filter to release built-up dust.
 - Check the air filter service indicator.
-

MAIN BROOM

Several different main brooms are available for this machine. Contact your advance dealer if you need help selecting the best broom for the surface and litter that you will be sweeping. Note: Reference broom maintenance for installation steps.

SCRUB BRUSHES

Raise the squeegee to allow access to the scrub brush area. Slide the scrub brushes under the four brush mounting plates and lift them so that the lugs in the brushes pass through the holes in the plates. Turn the brushes until they lock in place.

FILLING THE SOLUTION TANK

The solution tank fill (A), located at the left rear corner of the machine, has a 95 gallon (360 liter) capacity. Fill the tank with the proper dilution of cleaning Chemical mixed with water according to the manufacturer's recommendations. If using a powdered chemical, mix it with water in a bucket before putting it into the machine's solution tank.

CAUTION !

Use only low-sudsing, non-flammable, non-caustic cleaning chemicals intended for machine application.

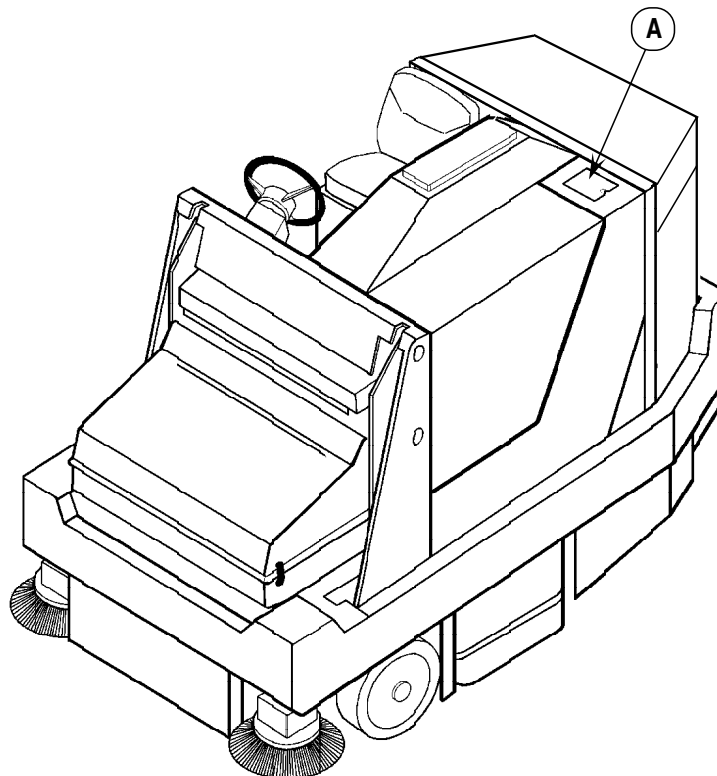

PREPARING THE MACHINE FOR USE

FUEL

WARNING !

- **ALWAYS STOP THE ENGINE BEFORE FILLING THE FUEL TANK.**
- **DO NOT SMOKE WHILE FILLING THE FUEL TANK.**
- **FILL THE FUEL TANK IN A WELL-VENTILATED AREA.**
- **DO NOT FILL THE FUEL TANK NEAR SPARKS OR OPEN FLAME.**
- **USE ONLY THE FUEL SPECIFIED ON THE FUEL TANK DECAL.**

On machines with diesel and gasoline engines, a decal near the filler neck shows the proper fuel to use in the machine. Before removing the cap from the tank, wipe all dust and dirt from the cap and from the top of the tank to keep the fuel as clean as possible.

Machines with propane engines have a mounting bracket for the propane tank under the driver's seat. A decal near the bracket gives specific information about the proper type of tank to be used on the machine.

MODEL 463685 (DIESEL ENGINE)

Fill the tank with Number 2 Diesel Fuel if the machine will be used in an area where the temperature is 30° Fahrenheit (0° Celsius) or higher. Use Number 1 Diesel Fuel if the machine will be used in an area where the temperature is below 30° Fahrenheit (0° Celsius).

NOTE: If the diesel machine runs out of fuel completely, the fuel system must be bled before the engine can be re-started. To avoid this situation, fill the fuel tank when the fuel gauge indicates 1/4 tank. Fuel tank capacity is 12 gallons (45 liters).

MODEL 463684 (GASOLINE ENGINE)

FILL THE TANK WITH UNLEADED 87 OCTANE REGULAR GASOLINE. FUEL TANK CAPACITY IS 12 GALLONS (45 LITERS).

Note: Reference the separately supplied engine manufacture's maintenance and operator manual for more detailed engine specification and service data.

MODEL 463683 (PROPANE ENGINE)

Mount a standard 33 lb. liquid withdrawal propane tank on the machine, connect the fuel hose and open the shutoff valve on the tank. Wear gloves when connecting or disconnecting the fuel hose. Shut the propane tank service valve OFF when the machine is not in use.

OPERATING THE MACHINE

The Hydro-Retriever 2067 is a rider-type automatic floor sweeping and scrubbing machine. It is designed to sweep up debris, lay down cleaning solution, scrub the floor, and vacuum dry all in one pass. The sweeping and scrubbing operations can also be performed separately. Reference specifications on page 26.

Note: Bold numbers in parentheses indicate an item illustrated on pages 7-8.

BEFORE STARTING THE MACHINE

- 1 Be sure you understand all machine controls and their functions.
- 2 Plan your cleaning route. Arrange long, straight passes with as few turns as possible.
- 3 Check the Brake Pedal **(21)**. The pedal should be firm. If the pedal is “spongy” or fades under pressure, **DO NOT DRIVE THE MACHINE**. Report all defects immediately to service personnel.

STARTING THE DIESEL ENGINE

- 1 Turn the Key Switch **(19)** counter-clockwise to the “Pre-Heat” position and hold it there for 15-30 seconds to warm the glow plug. A Glow Plug indicator **(31)** is mounted next to the Key Switch. This indicator will turn red to show it is properly pre-heated for cold starts. (Skip this step if the engine has been running and is already warm.)
- 2 Push the Throttle Lever **(3)** half-way forward.
- 3 Turn the Key Ignition Switch **(19)** clockwise to the START position and release it as soon as the engine starts. If the engine does not start after cranking for 15 seconds, release the key, wait for 1 minute and try steps 1-3 again.
- 4 Let the engine run at a moderate speed for 5 minutes before using the machine.
- 5 Push the Throttle Lever to the FULL THROTTLE position and move the machine around for 2 or 3 minutes at a slow speed to warm up the hydraulic system.

ALWAYS operate the machine with the Throttle Control Lever at full throttle. Use the Forward/Reverse Pedal **(23) - not the Throttle Control Lever - to control the **speed** of the machine. The speed of the machine will increase as the pedal is pushed closer to the floor. Do not press the Forward/Reverse Pedal until the engine has started.**

OPERATING THE MACHINE

STARTING THE GASOLINE ENGINE

- 1 Pull the Choke Knob (1) all the way up. (Skip this step if the engine has been running and is already warm.)
- 2 With the Throttle Control Switch (20) in the IDLE position (I), turn the Key Ignition Switch (19) clockwise to the START position and release it as soon as the engine starts. If the engine does not start after cranking for 15 seconds, release the key, wait for 1 minute, then try again.
- 3 Once started, push the Choke Knob down slowly until the engine runs smoothly.
- 4 Let the engine run with the Throttle Control Switch in the IDLE (I) position for 5 minutes before using the machine. Then push the Choke Knob all the way down.
- 5 Push the Throttle Control Switch to the FULL THROTTLE position (III) and move the machine around for 2 or 3 minutes at a slow speed to warm up the hydraulic system.

ALWAYS operate the machine with the Throttle Control Switch at full throttle. Use the **Forward/Reverse Pedal (23)** - not the Throttle Control Switch - to control the **speed** of the machine. The speed of the machine will increase as the pedal is pushed closer to the floor. Do not press the Forward/Reverse Pedal until the engine has started.

STARTING THE PROPANE ENGINE

- 1 Open the service valve on the LP fuel tank (29).
- 2 With the Throttle Control Switch (20) in the IDLE position (I), turn the Key Ignition Switch (19) clockwise to the START position and release it as soon as the engine starts. If the engine does not start after cranking for 15 seconds, release the key, wait for 1 minute, then try again.
- 3 Once started, let the engine run with the Throttle Control Switch in the IDLE position (I) for 5 minutes before using the machine.
- 4 Push the Throttle Control Switch to the FULL THROTTLE position (III) and move the machine around for 2 or 3 minutes at a slow speed to warm up the hydraulic system.

ALWAYS operate the machine with the Throttle Control Switch at full throttle. Use the **Forward/Reverse Pedal (23)** - not the Throttle Control Switch - to control the **speed** of the machine. The speed of the machine will increase as the pedal is pushed closer to the floor. Do not press the Forward/Reverse Pedal until the engine has started.

OPERATING THE MACHINE

SWEEPING

- 1 Push the Hopper Raise/Lower Switch **(18)** to the DOWN position to make sure the hopper is seated properly.
- 2 Move the Main Broom Lever **(4)** to the SWEEP (middle notch) position.
Use the FULL FLOAT (last notch forward) position only when sweeping extremely rough or uneven floors. Use at other times will only increase broom wear.
- 3 Push the Broom Motor Switch **(8)** ON to start the broom motors.
- 4 When sweeping dry floors, put the Dust Control Lever **(2)** to the ON position.
When sweeping floors with puddles, push the Dust Control Lever **(2)** to the OFF position before the machine enters a puddle. Put the lever back to the ON position when the machine is back on completely dry floor.
When sweeping wet floors, keep the Dust Control Lever **(2)** in the OFF position.
- 5 Lower the side broom **(10)** when sweeping along walls or curbs. Raise the side broom when sweeping in open areas.
- 6 Adjust the Side Broom Speed Lever **(28)** so that the side broom turns just fast enough to move debris away from walls or curbs and into the path of the main broom. Operating the side broom at the minimum effective speed will keep dust to a minimum.
- 7 Drive the machine straight forward at a quick walking speed. Drive the machine slower when sweeping large amounts of dust or debris or when safe operation dictates slower speeds. Overlap passes 6 inches (15 cm).
- 8 If dust comes out of the broom housing while sweeping, the dust control filter may be clogged. The filter shaker will stop automatically, 15 seconds after the lever is released. Leave the lever in the forward position until the shaker stops. Then move the lever back to the DUST CONTROL ON position and continue sweeping.
- 9 Check behind the machine occasionally to make sure that the machine is picking up debris. Dirt left behind in the path of the machine usually indicates that the machine is moving too fast, the broom needs to be adjusted, or the hopper is full.

EMPTYING THE HOPPER

- 1 Turn the Broom Motor Switch **(8)** OFF.
- 2 Put the Main Broom Lever **(4)** to the UP position and raise the side broom.
- 3 Push the Dust Control Lever **(2)** forward to the SHAKE position. This will operate the filter shaker motor for 15 seconds. Do not move the lever until the shaker stops.
- 4 Drive the machine close to a large trash receptacle and hold the Hopper Raise/Lower Switch **(18)** in the UP position until the hopper is all the way up.
- 5 Move the machine until the hopper is over the receptacle, then press the Hopper Dump Door Switch **(17)** to open the dump door. Close the dump door when the hopper is empty.
- 6 Check the back of the hopper and the front of the broom housing. Use a broom, if necessary, to remove litter from these areas. The back of the hopper must seal tightly against the front of the broom housing for proper operation.
- 7 Back the machine away from the receptacle until the hopper will clear it, then lower the hopper.

OPERATING THE MACHINE

SCRUBBING

- 1 Push the Hopper Raise/Lower Switch (**18**) to the DOWN position to make sure the hopper is seated properly.
- 2 Put the Scrub Brush Switch (**7**) in the DOWN (ON) position. The brush drive assembly will lower to the floor and the brush motor will start automatically.
- 3 Position the Solution Control Lever (**11**) half-way toward the front of its slot and drive the machine forward with the squeegee up. Then stop the machine and look at the scrubbed area. There should be a thin, even layer of solution on the floor behind the machine. If there are dry spots in the scrubbing path, push the lever forward for more solution. If the path of water on the floor is wider than the machine, pull the lever back for less solution. Once you find the best solution flow, note the position of the Solution Control Lever for future reference.
- 4 Lower the squeegee (**9**).
- 5 Begin scrubbing with a slow, even forward pedal pressure. Overlap passes 6 inches (15 cm). Turns may be made with all functions operating. When backing up, the squeegee will raise automatically to prevent squeegee blade damage. You may want to shut the solution flow OFF to prevent solution accumulation on turns.

Drive the machine forward at a normal walking speed for normal scrubbing. If the floor is still dirty behind the machine, drive slower. For very dirty floors, "double scrubbing" may be necessary. Double scrubbing is the same as normal operation, only the squeegee is left in the up position. This allows the cleaning solution more time to work on the floor. Then make a second pass with the squeegee down to scrub again and pick up the solution. Do not "double scrub" too large of an area, or the solution will dry on the floor before the second pass.

Check behind the machine occasionally to see if all the solution is being picked up. If there is water trailing the machine you may be dispensing too much solution, the recovery tank may be full or the squeegee tool may need adjustment. Note: The recovery tank has an automatic float shut-off to block the vacuum system. You can tell when the float closes by the sudden change in the sound of the vacuum impeller. When the float closes, the recovery tank must be emptied. The machine will not pick up water with the float closed.

- 6 With a full recovery tank, Turn off the solution flow, raise the scrub brushes, the squeegee and the sweeping broom. Then drive the machine to a proper disposal site to empty the recovery tank.

EMPTYING THE RECOVERY TANK

- 1 Drive the machine to a proper disposal site.
- 2 Remove the drain hose from its storage compartment (lower right side of machine, behind main broom access door).
- 3 Direct the hose to a proper disposal site, remove the drain plug.
- 4 Flush the tank and drain hose with clean water.
- 5 Put the plug back into the hose and return the hose to its storage compartment.

AFTER USING THE MACHINE

AFTER USE

- 1 Raise the squeegee, the scrub brushes, and the brooms.
- 2 Shake the dust control filter and empty the hopper.
- 3 Drain and flush the recovery tank.
- 4 Flush the vacuum hose and squeegee.
- 5 Remove and clean the squeegee tool.
- 6 Remove and clean the scrub brushes. Rotate the scrub brushes.
- 7 Wipe the machine with a damp cloth.
- 8 Perform all required maintenance before storage.
- 9 Move the machine to a clean, dry storage area.
- 10 Store the machine with the brooms, the squeegee and the scrub brushes in the UP position, and the tank covers open so that the tanks can air out.

REPORT ANY DEFECT OR MALFUNCTION NOTED DURING OPERATION TO AUTHORIZED SERVICE OR MAINTENANCE PERSONNEL.

SHUTTING DOWN THE DIESEL/ GASOLINE ENGINE

- 1 Put all controls to the OFF position.
 - 2 Raise the squeegee, the scrub brushes, and the brooms.
 - 3 Place the Throttle Control Switch or Lever in the IDLE position and let the engine idle for 30 seconds.
 - 4 Apply the Parking Brake.
 - 5 Turn the Key Ignition Switch OFF and remove the key.
-

SHUTTING DOWN THE PROPANE ENGINE

- 1 Put all controls to the OFF position.
- 2 Raise the squeegee, the scrub brushes, and the brooms.
- 3 Turn the service valve on LP gas tank OFF.
- 4 Place the Throttle Control Switch in the IDLE position and run the engine until all the LP gas is dispelled from the line.
- 5 Apply the Parking Brake.
- 6 Turn the Key Ignition Switch OFF and remove the key.

MAINTENANCE

MAINTENANCE SCHEDULE

Keep the machine in top condition by following the maintenance schedule closely. Maintenance intervals given are for average operating conditions. Machines used in severe environments may require service more often.

EVERY 15 HOURS OF OPERATION

- 1 Check the engine coolant level.

CAUTION !

Do not remove the radiator cap when the engine is hot.
Be sure the engine cover is engaged before working under the engine cover.

- 2 Check the hydraulic oil level.

IMPORTANT !

Change the hydraulic oil filter after the first 30 hours of operation. After that, change the filter when the hydraulic filter light comes on.

- 3 Drain and flush the solution tank.
-

EVERY 30 HOURS OF OPERATION

- 1 Inspect the main broom, rotate if the bristles are curved.
 - 2 Adjust the main broom height.
 - 3 Inspect the dust control filter. clean using method "A" if necessary. (see page 25.)
 - 4 Adjust the side broom.
 - 5 Blow dust from the radiator and oil cooler.
 - 6 Check the oil in the upper impeller shaft housing.
-

EVERY 100 HOURS OF OPERATION

- 1 Change the engine oil and oil filter.
 - 2 Inspect the dust control filter. clean using method "B" if necessary. (see page 25.)
 - 3 Lubricate the grease fittings.
-

EVERY 300 HOURS OF OPERATION

- 1 Inspect the dust control filter. Clean using method "C" if necessary. (see page 25.)
 - 2 Change the oil in the upper impeller shaft housing.
-

EVERY 1500 HOURS OF OPERATION

- 1 Drain and flush the cooling system. Add new coolant.
-

MAIN BROOM MAINTENANCE

Since the main broom motor always turns in the same direction, the broom bristles eventually become curved. Curved bristles will reduce sweeping performance. Improve sweeping performance by removing the broom and turning it end-for-end. This procedure, known as “rotating” the main broom, should be done whenever the bristles become curved.

Replace the main broom when the bristles are worn to a length of 2 inches (5 cm). Adjust the height of the main broom whenever the broom is replaced.

To rotate or replace the main broom...

- 1 Turn the key ignition switch off to stop the engine.
- 2 Put the main broom lever in the sweep position.
- 3 Remove the tool stored under the driver's seat.
- 4 Open the main broom access door (located on the right side of the machine under the operator's compartment).
- 5 Remove the Bolt (A) that holds the broom idler arm in place. then pull the idler arm out of the broom core.
- 6 Pull the main broom out of the broom housing and remove any string or wire wrapped around it. Also inspect the skirts at the front, back and sides of the broom housing. Replace the skirts if they are torn.
- 7 Turn the broom around (end-for-end) and slide it back into the broom housing. Make sure that the lugs on the broom drive hub (on the left side of the machine) engage the slots in the broom core.
- 8 Put the idler arm back into the broom core and use the tool to tighten the bolt that holds it in place.
- 9 Close and latch the door securely and put the tool back into the storage clips.

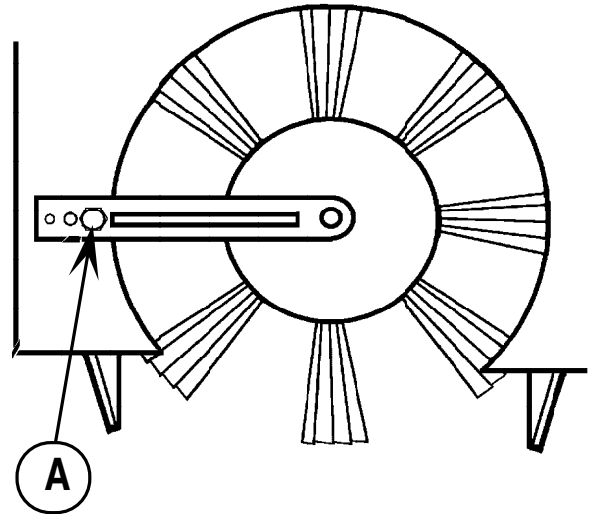

To Adjust the Main Broom...

- 1 Drive the machine to an area with a level floor and set the parking brake.
- 2 Put the broom motor switch in the on position and the main broom lever in the sweep (middle notch) position. do not move the machine.
- 3 Let the main broom run in place for 1 minute. This allows the broom to polish a “strip” on the floor. After 1 minute, raise the broom, release the parking brake and move the machine so that the polished strip is visible.
- 4 Inspect the polished strip on the floor.
If the strip is less than 2-1/2 inches (6.3 cm) wide, turn the Main Broom Adjustment Knob (B) clockwise 2 or 3 turns.
If the strip is more than 2-1/2 inches (6.3 cm) wide, turn the Main Broom Adjustment Knob (B) counter-clockwise 2 or 3 turn.
- 5 Repeat steps 1-4 until the polished strip is 2-1/2 inches (6.3 cm) wide.

The width of the polished strip should be the same at both ends of the broom. If the strip is tapered, move the machine to a different area and repeat steps 1-4. If the polished strip is still tapered, contact your Advance Dealer for service.

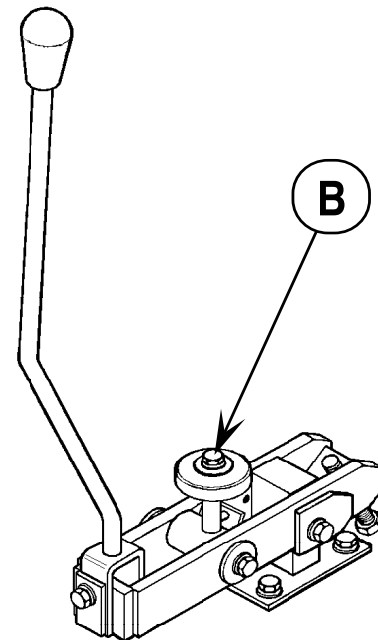

MAINTENANCE

SIDE BROOM MAINTENANCE

The side broom moves dirt and debris away from walls or curbs and into the path of the main broom. The side broom works best when 1/3 of its bristles are touching the floor while the broom is down and running. Adjust the side broom so that only the bristles in area "a" touch the floor when the broom is down and running.

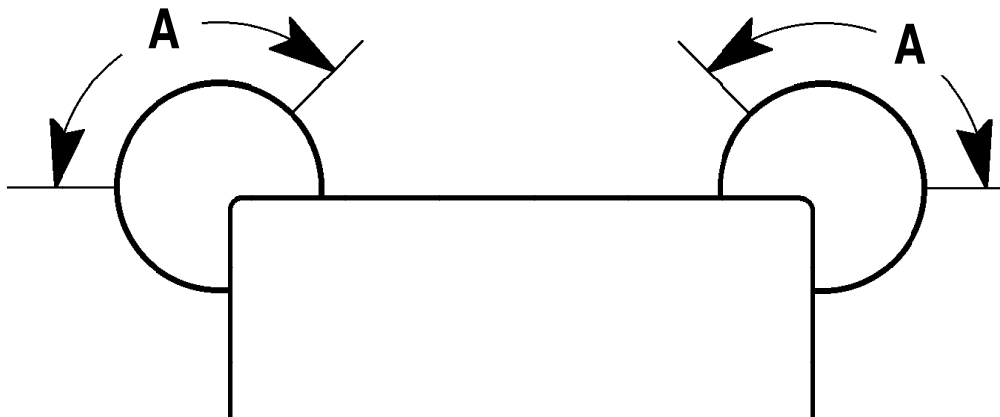

- To adjust the front-to-back side broom angle, loosen Lock Nut (F) and turn Bolt (B).
- To adjust the side-to-side side broom angle, loosen the (2) (C) Bolts and tip the motor mount to the desired angle, then tighten the bolts.
- To raise or lower the side broom (without changing its angle), loosen Bolt (D) and the lock nut on Bolt (E). Turn Bolt (E) clockwise to lower or counter-clockwise to raise the broom. Tighten Bolt (D) and the Locknut (G) when adjustment is complete.

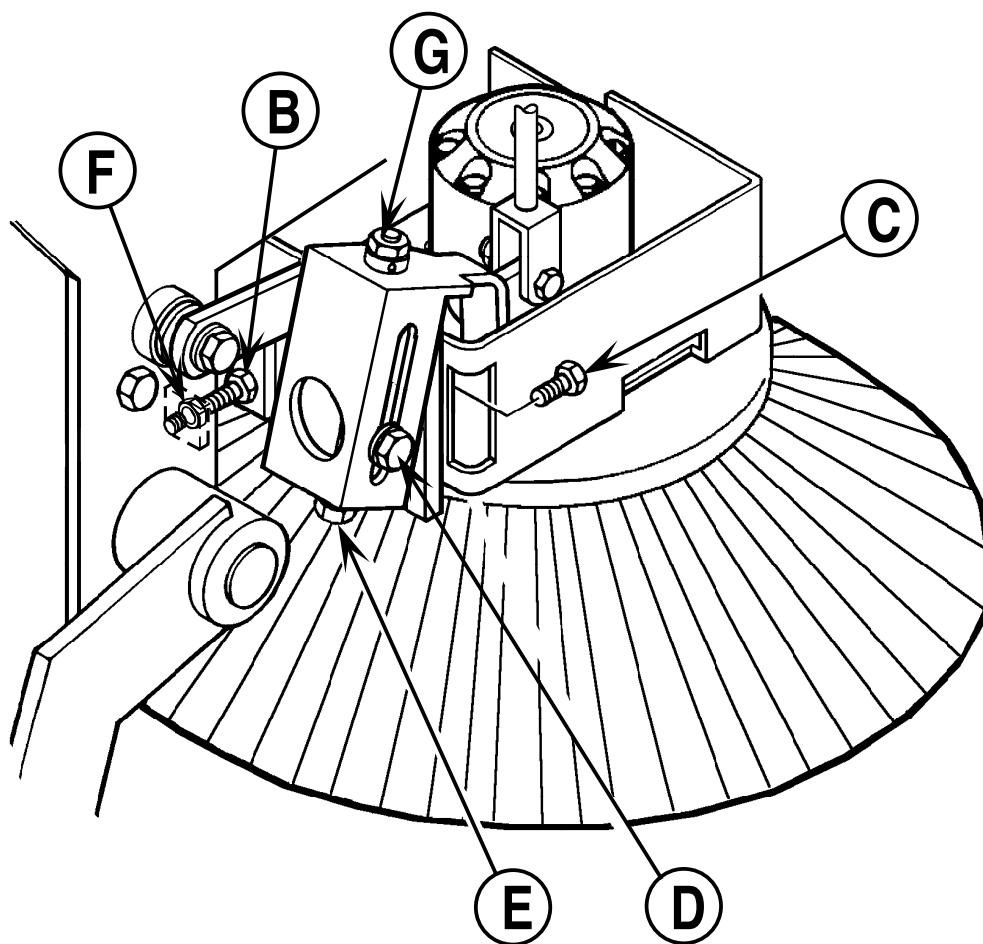

SQUEEGEE MAINTENANCE

After each use, clean the squeegee tool and check the blades for damage. The rear squeegee blade has 4 working edges. Turn the blade so a clean, undamaged edge points toward the front of the machine and against the floor. Replace the blade if all 4 edges are necked, torn or worn to a radius. If the squeegee leaves water in the middle of its path or at both ends of its path, it probably needs to be adjusted.

To adjust the squeegee...

- 1 Park the machine on a level floor and lower the squeegee.
- 2 Loosen the four Squeegee Adjustment Bolts (**A**).
- 3 Pivot the squeegee tool until the squeegee blades touch the floor evenly across the entire width of the squeegee tool. Then tighten the four bolts.
- 4 Adjust the height of the Squeegee Support Wheels (**B**) so the squeegee blades contact the floor at a 45° angle when they are bent over to their "operating position". Move the wheels up to lower the squeegee or down to raise the squeegee.

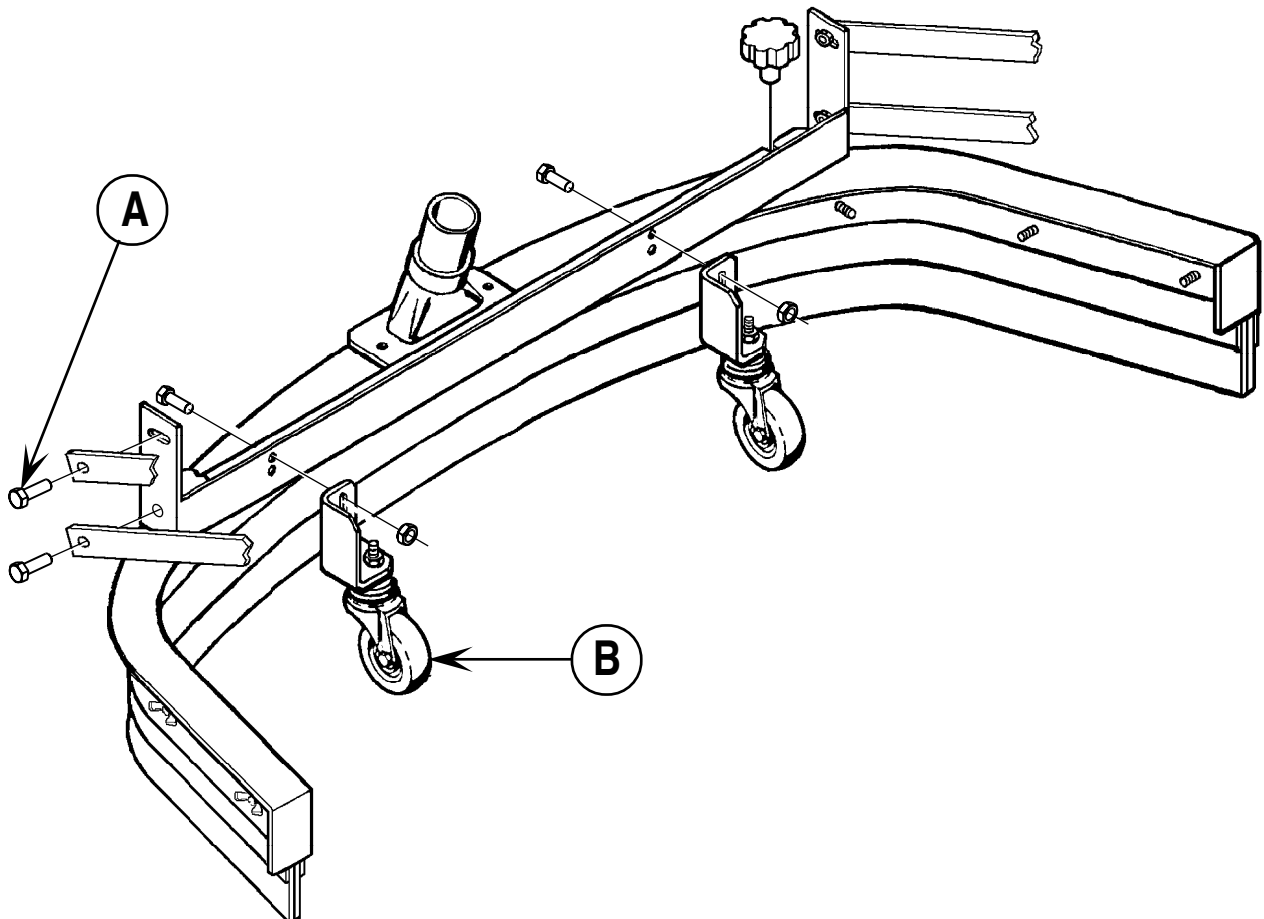

MAINTENANCE

IMPELLER MAINTENANCE

Check the oil level in the upper impeller shaft housing every 30 hours of operation. The upper impeller shaft housing is located in the upper left corner of the engine compartment. Oil should seep from Oil Level Plug (A) when removed. If oil is low, remove the filler cap and add SAE 90 weight gear lube to plug height.

Every 300 hours, drain the oil from the upper impeller shaft housing (B). Refill with SAE 90 weight gear lube to the Oil Level Plug (A).

Inspect the two belts between the engine and the lower impeller shaft. Adjust the tension or replace the belts if necessary.

Inspect the belt between the lower impeller shaft and the upper impeller shaft. Adjust the tension or replace the belt if necessary.

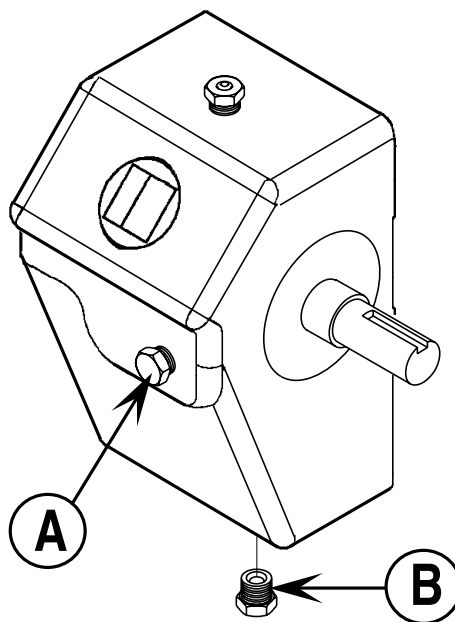

LUBRICATION

Lubricate the two Grease Fittings (C) on the lower impeller shaft every 150 hours of operation. These can be easily lubricated with a grease gun from the engine compartment.

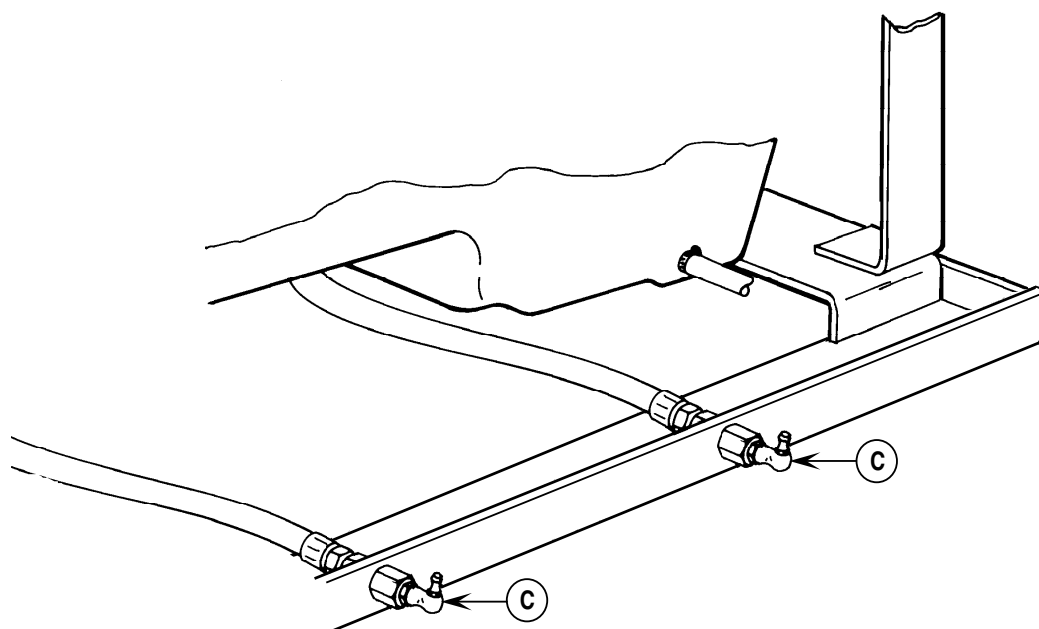

HYDRAULIC OIL

The hydraulic oil tank is located under the operator's seat. Remove the cap from the tank and look to the bottom of the filler screen. If the oil level is below the bottom of the filler screen, add SAE 10W-30 motor oil until the bottom of the filler screen is covered. Change the oil if major contamination from a mechanical failure occurs.

ENGINE OIL

Check the engine oil level when the machine is parked on a level surface and the engine is cool. Change the engine oil after the first 35 hours of operation and every 100 hours after that. Use 3.5 quarts (3.3 liters) of 10W-30 motor oil (API service SG-SF). Replace the oil filter with every oil change.

ENGINE COOLANT

Lift the engine cover and allow the engine to cool completely. Then remove the cap from the radiator. If coolant is not visible at the bottom of the filler neck, add a mixture of half water and half automotive type anti-freeze.

MAINTENANCE

ENGINE AIR FILTER

The engine air filter is located in the engine compartment. Check the air filter Service Indicator (A) before each use of the machine. Do not service the air filter unless the red flag is visible in the service indicator.

⚠ CAUTION !

When servicing the engine air filter elements, use extreme caution to prevent dust from entering the engine.

The engine air filter contains a Primary (B) (outer) and a Safety (C) (inner) filter element. The primary element may be cleaned twice before being replaced. Replace the safety element every third time that the primary filter element is serviced. Never try to clean the safety element.

To clean the primary filter element, remove the Cover (D) from the dust cup end of the canister. Then pull out the Primary (B) element. Clean the element with compressed air (maximum pressure 100 psi) or wash it with water (maximum pressure 40 psi). Do not put the element back into the Canister (E) until it is completely dry. To reset the air filter service indicator, press down on the top of the indicator.

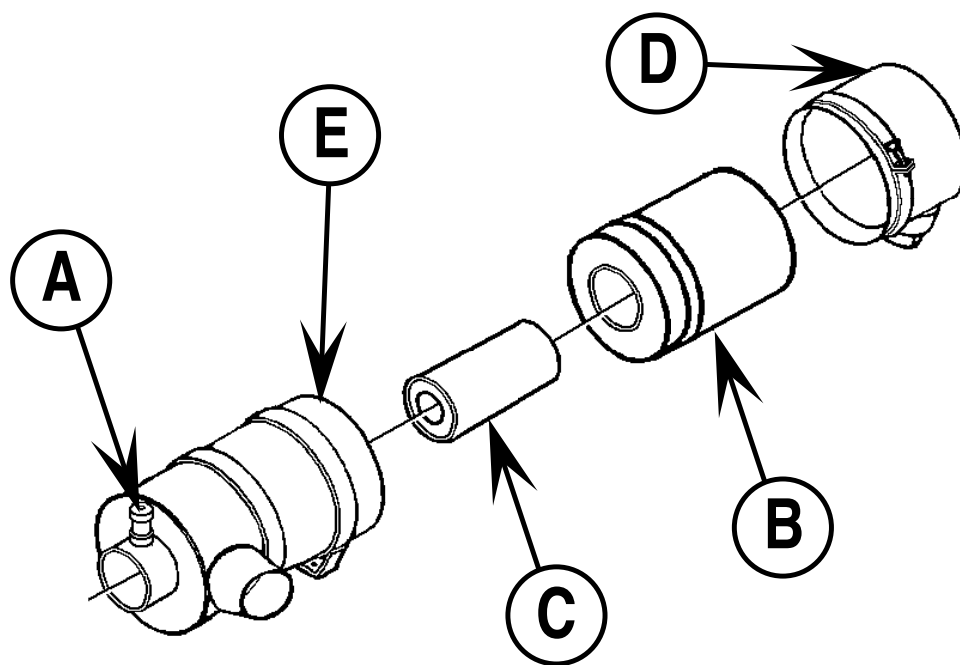

DUST CONTROL PANEL FILTER

Inspect and clean the dust control panel filter regularly to maintain the efficiency of the vacuum system. Follow the recommended filter service intervals for the longest filter life.

⚠ CAUTION !

Wear safety goggles when cleaning the filter.

Do not puncture the paper filter.

Clean the filter in a well-ventilated area.

To remove the dust control filter...

- 1 Open the dust control filter compartment.
- 2 Inspect the top of the Filter (A) for damage. A large amount of dust on top of the filter is usually caused by a hole in the filter or a damaged filter gasket. A damaged filter or gasket must be replaced.
- 3 Disconnect the Wire Connector (B) for the shaker motor.
- 4 Lift the red handles on the two Latches (C) (one on each side) to release the Shaker Frame (D), then lift the shaker frame out of the filter compartment.
- 5 Using the Lift Rings (E), pull the filter straight up and out of the machine.
- 6 Clean the filter using one of the methods below:

METHOD "A"

Vacuum loose dust from the filter. Then gently tap the filter against a flat surface (with the dirty side down) to remove dust and dirt.

METHOD "B"

Vacuum loose dust from the filter. then blow compressed air (maximum pressure 100 psi) into the clean side of the filter (in the opposite direction of the airflow).

METHOD "C"

Vacuum loose dust from the filter. then soak the filter in warm water for 15 minutes and rinse it under a gentle stream of water (maximum pressure 40 psi). Let the filter dry completely before putting it back into the machine.

- 7 Follow the instructions in reverse order to put the filter back into the machine.

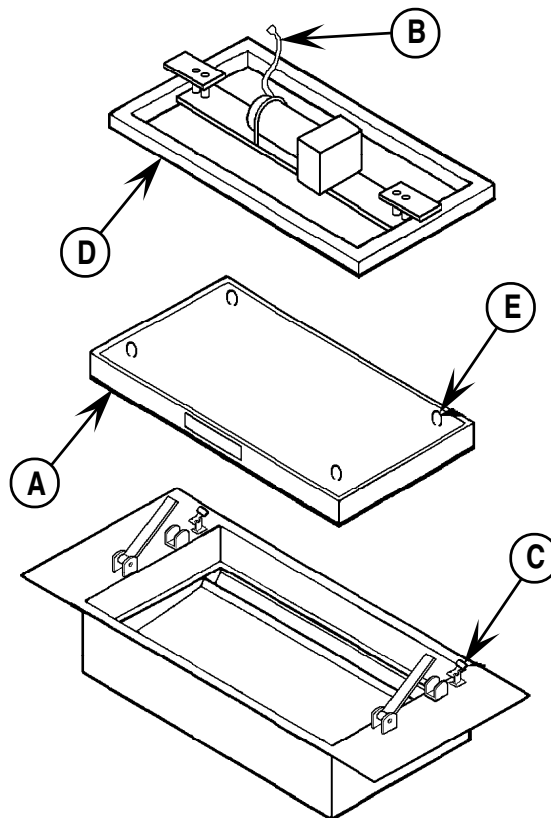

FUSE LOCATION

Electrical fuses are located under the front dash of the operator's compartment.

- F1 - 30 amp fuse - ignition
- F2 - 15 amp fuse - headlights
- F3 - 15 amp fuse - horn
- F4 - 10 amp fuse - optional accessories
- F5 - 15 amp fuse - hydraulics, beacon, timer
- F6 - 20 amp fuse - shaker motor, turn signals (optional)
- F7 - 20 amp fuse - optional accessories
- F8 - 10 amp fuse - optional accessories

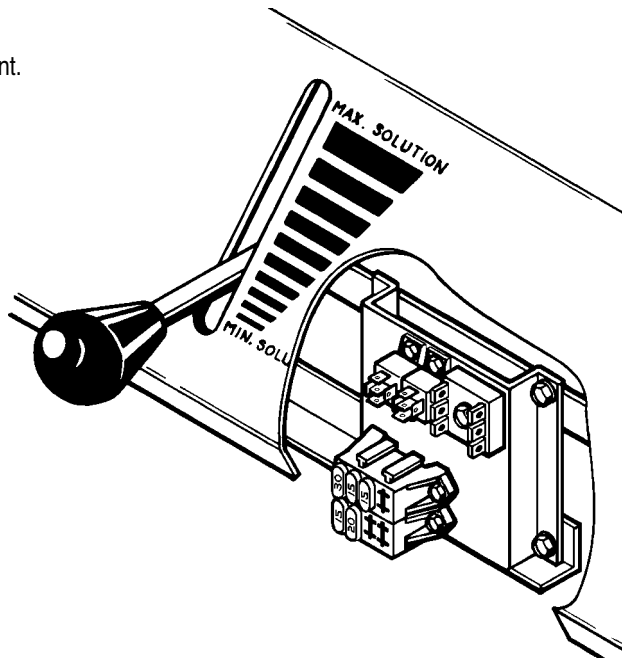
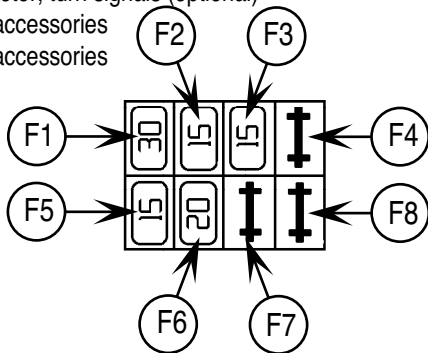

SPECIFICATIONS

Length	108 inches (275 cm)
Width	58 inches (148 cm)
Height	67 inches (170 cm) 87 inches (220 cm) with optional overhead guard
Weight	4000 pounds net (1814 kg), 4250 pounds shipping (1928 kg)
Main Broom	16 inch (40 cm) diameter 45 inches (114 cm) long
Side Broom	21 inch (53 cm) diameter
Sweeping Path	67 inches (170 cm) with dual side brooms
Hopper Capacity	1200 pounds (544 kg) 15 cubic feet (425 liters)
High Dump	multi-level from 18" - 60" (46 cm - 152 cm)
Dust Control	10" (25 cm) impeller, dual-stage dust control system with pre-filter grid and pleated paper panel 125 square feet (11.6 square meters)
Scrub Brushes	four 12 inch (30 cm) diameter brushes
Scrubbing Path	45 inches (114 cm)
Scrubbing Action	200 rpm 350 pounds (159 kg) of down pressure
Solution Tank Capacity	95 gallons (360 liters)
Recovery Tank Capacity	85 gallons (322 liters)
Speed	8 mph (13 kph) maximum forward transport speed 4 mph (6.5 kph) maximum reverse transport speed

System Fluid Capacities

Engine Oil	3.5 quarts (3.3 liters) with filter
Engine Cooling System	12 quarts (11.4 liters) radiator
Hydraulic System	11 gallon (41.5 liters) reservoir 12.5 gallon (47 liters) total system
Fuel	12 gallons (45.4 liters) diesel 12 gallons (45.4 liters) gasoline 33 pound (15 kg) LPG
Gradeability	
Transport	14% (8°)
Cleaning	10% (6°)

Specifications are subject to change without notice.



Nilfisk-Advance, Inc.
14600 21st Avenue North
Plymouth, MN, 55447-3408
www.nilfisk-advance.com
Phone: 800-989-2235
Fax: 800-989-6566
©2000 Nilfisk-Advance, Inc.,
Plymouth, MN 55447-3408
Printed in the U.S.A.