



## Electronic Service Manuals

This electronic document is provided as a service to our customers. We do not create the contents of the information contained in this document. Should you have detailed questions pertaining to the information contained in this document, you may contact Michco, or the manufacturer which provided the original information in this electronic deliverable. Michco's only part in this electronic deliverable was the electronic assembly process.

You may contact Michco through the following methods:  
Phone (517) 484-9312 or (800) 331-3339 MI, OH, IN only  
2011 N. High St. -- Lansing, Michigan -- 48906  
Fax: (517) 484-9836  
Email: [CustServ@Michco.com](mailto:CustServ@Michco.com)  
Web site: [www.Michco.Com](http://www.Michco.Com)  
Parts Web site: [www.FloorMachineParts.Com](http://www.FloorMachineParts.Com)

Order Parts on Line at:  
**[www.FloorMachineParts.Com](http://www.FloorMachineParts.Com)**

Directly to Parts & Service:  
By Email: **[Shop@Michco.com](mailto:Shop@Michco.com)**  
By Fax: (517) 702-2041  
By Voice: Use numbers above.

**Serving the Cleaning Industry Since 1922**

Notice: All copyrighted material remains property of original owners, all trademarks are property of respective owners. Manuals are subject to Manufacturer's reproduction limitations. Originals or reproductions were provided by manufacturers through a request. We make no warranty as to the correctness of information provided in this document and you assume all risk.

# Micromatic™ 17B

---

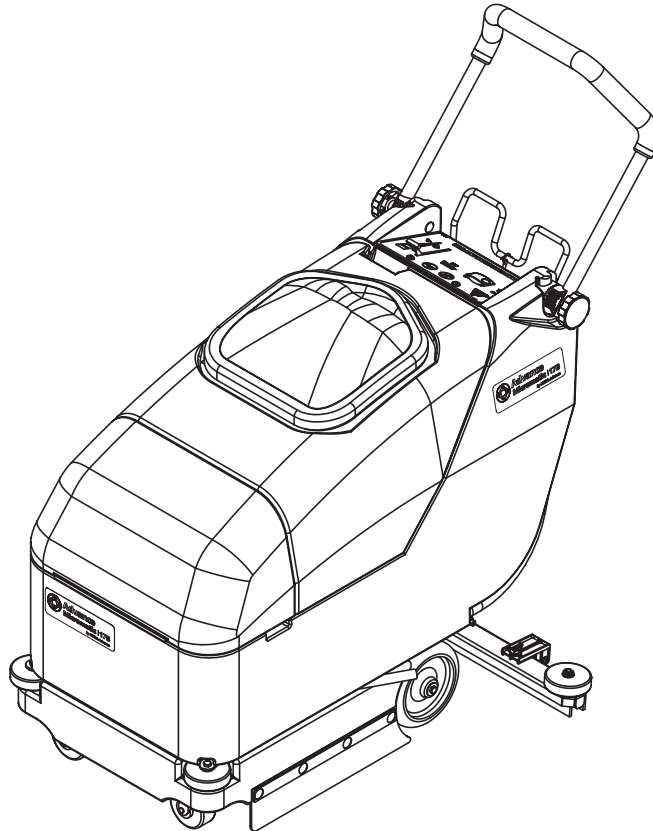

## **PARTS LIST**

**Advance MODEL 56302100**

**This parts list is for machines after serial number 1153373**



**Advance**

*by Nilfisk-Advance*

9/96 revised 8/01 FORM NO. 56042317

<b>DESCRIPTION</b>	<b>PAGE</b>
Chassis System .....	4-5
Solution System .....	6-7
Recovery System .....	8-9
Squeegee System .....	10-11
Brush Drive System .....	12-13
Electrical System / Wiring Diagram .....	14-15

#### WHEN ORDERING PARTS

- \* Use the 8 digit numbers from the "Ref. No." columns in this parts list.
- \* Specify the model and serial number of the machine.
- \* Use the space below to record the model and serial number for future reference.

Model \_\_\_\_\_ Serial No. \_\_\_\_\_



96-9	<b>CHASSIS SYSTEM</b>		
00-1	<b>Micromatic™ 17B</b>		<b>5</b>

Item	Ref. No.	Qty	Description
1	56001939	12	Wsh, Flt SAE 5/16
2	56001967	2	Scr, Hex Hd 1/4-20 x 1.75
3	56002913	4	Scr, Hex Hd SS 5/16-18 x 1.00
4	56002992	4	Scr, Hex Hd SS 5/16-18 x .50
5	56003119	6	Scr, Pan Phil SS 1/4-20 X .50
6	56003333	3	Scr, Hex SS 5/16-18 X 1.75
7	56003334	1	Scr, Hex SS 5/16-18 X 3.00
8	56009033	4	Scr, Hex Thd Form 1/4-20 X .50
9	56009097	2	Nut, Push Cap 1/2
10	56200754	32.5"	Gasket, RS Strip (82.55 cm)
11	56302101	1	Caster Mount
12	56302104	1	Control Panel
13	56302116	1	Battery box
14	56302132	2	Bracket, Wheel
15	56302135	2	Strap
16	56302139	1	Skirt
17	56302143	1	Battery Tray
18	56302151	2	Wheel
19	56302152	2	Caster ( <b>before February 2000</b> )
	56302319	2	Wheel, Caster ( <b>after January 2000</b> )
20	56302157	2	Blade
21	56302183	8	Clip, Panel
22	56324499	2	Wheel 3.00
23	56360139	2	Bushing
24	56900236	1	Tie, Pushmount
25	56015904	1	Decal, Control Panel
26	56015917	1	Decal, Cable Routing
27	56302189	1	Gasket
28	S90007	6"	Electrical Tape (15.25 cm)
29	56302193	4	Spacer
30	56302192	1	Spacer
31	56302191	3	Spacer
32	56302248	2	Clip
33	56009012	2	Scr, Hex Thd Form 10-24 x .38
34	56302249	1	Kickstand Weldment
35	56302247	1	Rod
36	56302244	1	Tip, Rubber
37	56016077	1	Decal, Wear Items Micromatic 17B

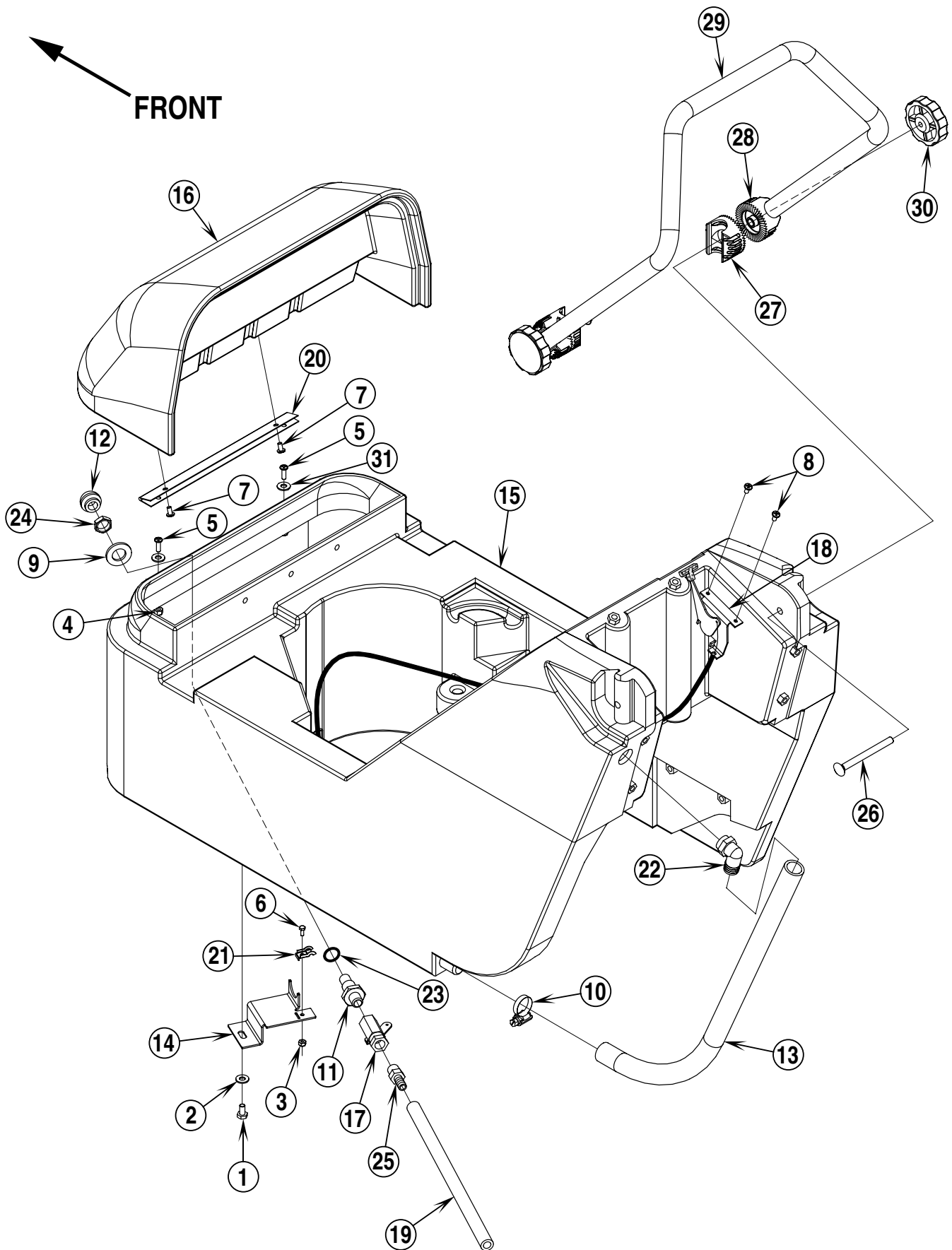

96-9	<b>SOLUTION SYSTEM</b>		
01-2	<b>Micromatic™ 17B</b>		<b>7</b>

Item	Ref. No.	Qty	Description
1	56001854	1	Scr, Hex Hd 1/4-20 X .50
2	56002098	1	Wsh, Flt SAE 1/4
3	56002830	1	Nut, Hex Nyl Loc 6-32
4	56002836	2	Nut, Hex Nyl Loc SS 10-24
5	56002896	2	Scr, Pan Phil SS 10-24 x .62
6	56003068	1	Scr, Hex hd 6-32 x .38
7	56003189	2	Scr, Pan Phil SS 10-24 x .38
8	56009030	2	Scr, Pan Phil Thd Form 10-24 x .38
9	56009218	1	Wsh, Flt .68 x 1.25 x .12
10	56112771	1	Hose Clamp
11	56172075	1	Nipple, 1/4 NPT x 5/8-18
12	56172096	1	Strainer <b>(solution)</b>
13	56228400	1	Solution Drain Hose
14	56302133	1	Bracket, Cable
15	56302137	1	Solution Tank
16	56302140	1	Cover, Solution Tank
17	56302158	1	One-Way Ball Valve <b>(solution)</b>
18	56302159	1	Control Cable <b>(solution valve)</b>
19	56302161	1	Solution Feed Hose
20	56302168	1	Hinge
21	56344265	1	Clamp, Cable
22	56456802	1	Barb, 90° Elbow 11/16 x 3/4 NPT
23	56742552	1	O-Ring
24	56745860	1	Nut, Jam 5/8-18 Brass
25	56900034	1	Barb, Adapter 3/8 x 1/4 NPT
26	56009227	2	Scr, Carriage 5/16-18 x 3.50
27	56264123	2	Ratchet
28	56264118	2	Ratchet
29	56302150	1	Handle Tube
30	56302167	2	Knob
31	56009011	2	Wsh, Int Shprf #10



96-9	<b>RECOVERY SYSTEM</b>		
01-2	<b>Micromatic™ 17B</b>		<b>9</b>

Item	Ref. No.	Qty	Description
1	56002850	3	Nut, Hex Nyl Loc-Thin 1/4-20
2	56002859	8	Wsh, Flt SAE SS 1/4
3	56002901	4	Scr, Hex Hd SS 1/4-20 x 1.50
4	56003047	6	Scr, Hex Hd SS 1/4-20 x .62
5	56003293	2	Rivet, Pop
6	56003145	4	Nut, Hex Jam 1/4-20
7	56003125	2	Scr, Hex Thd To Hd 1/4-20 x 1.25
8	56009098	2	Wsh, Flt .12 x .50 x .03
9	56131601	1	Clamp, Hose SAE #16
10	56209547	1	Clamp, One Ear, 1.75
11	56261266	1	Tube
12	56209506	1	Drain Plug
13	56302551		41" Gasket (102 cm)
14	56262574	1	Hose, Squeegee
15	56302136	1	Recovery Tank Cover
16	56302138	1	Recovery Tank
17	56302141	1	Vac Motor Duct
18	56302142	1	Float Duct
19	56302154	1	Hinge
20	56302165	1	Gasket
21	56302182	1	Gasket
22	56324489	1	Vac Motor Assembly
*	56503003	1	Carbon Brush Set
23	56324497	2	Cage, Float (2 piece)
24	56329145	1	Clamp, Hose SAE #24
25	56386035	1	Hose, Recovery Tank Drain
26	56391690	1	Ball, Float
27	56391807	1	Hose, Vac Exhaust
28	56409535	1	Strap, Retaining
29	56477613	1	Tie, Cable



96-9	<b>SQUEEGEE SYSTEM</b>		
02-8	<b>Micromatic™ 17B</b>		<b>11</b>

Item	Ref. No.	Qty	Description
1	56003332	3	Pin, Cotter Hair .04 x .18
2	56003391	2	Pin, Groove .09 x .62
3	56009123	2	Nut, Push Cap 3/8
4	56302127	1	Squeegee Mount
5	56302131	1	Pivot Bracket
6	56302153	1	Gas, Spring ( <b>cylinder</b> )
7	56302162	1	Cable Assembly ( <b>squeegee lift</b> )
8	56302164	2	Bearing, Flange
9	56003191	1	Clevis, Pin .50 x 3.00
10	56003192	3	Clevis, Pin .250 x 2.00
11	56302190	1	Handle ( <b>squeegee lift</b> )
12	56003222	1	Pin, Cotter Hair
	56302145	1	Squeegee Assembly ( <b>#13-30</b> )
13	56002098	2	Wsh, Flt SAE 1/4
14	56003037	2	Scr, Pan Phil SS 1/4-20 x .25
15	56003067	2	Scr, Pan Phil SS 1/4-20 x 1.00
16	56003269	2	Ring, Retainer
17	56009047	4	Wsh, Flt .39 x .62 x .06
18	56009048	2	Nut, Wing Loc 1/4-20
19	56105569	2	Blade, Molded
20	56302146	1	Squeegee Tool
21	56302323	1	Channel
22	56302324	1	Retainer
23	56324499	2	Wheel 3.00
24	56370711	2	Nut, Thumb
25	56387376	2	Roller Assembly
26	56400613	1	Gasket
27	56400614	2	Gasket
28	56003119	2	Scr, Pan Phil SS 1/4-20 x .50
29	56302316	2	Squeegee Housing
30	56302315	2	Squeegee Cartridge
31	56302180	1	Channel, Squeegee Blade ( <b>before February 2000</b> )
32	56302181	1	Retainer, Squeegee Blade ( <b>before February 2000</b> )
33	56002859	2	Wsh, Flt SAE SS 1/4
	56302197	A/R	Squeegee Blade Cartridge ( <b>for machines built before February 2000</b> ) ( <b>items 14, 15, 19, 26, 27, 31 &amp; 32</b> )
	56302326	A/R	Squeegee Cartridge Assembly ( <b>for machines built after January 2000</b> ) ( <b>items 14, 15, 18, 19, 21, 22, 28, 29, 30 &amp; 33</b> )

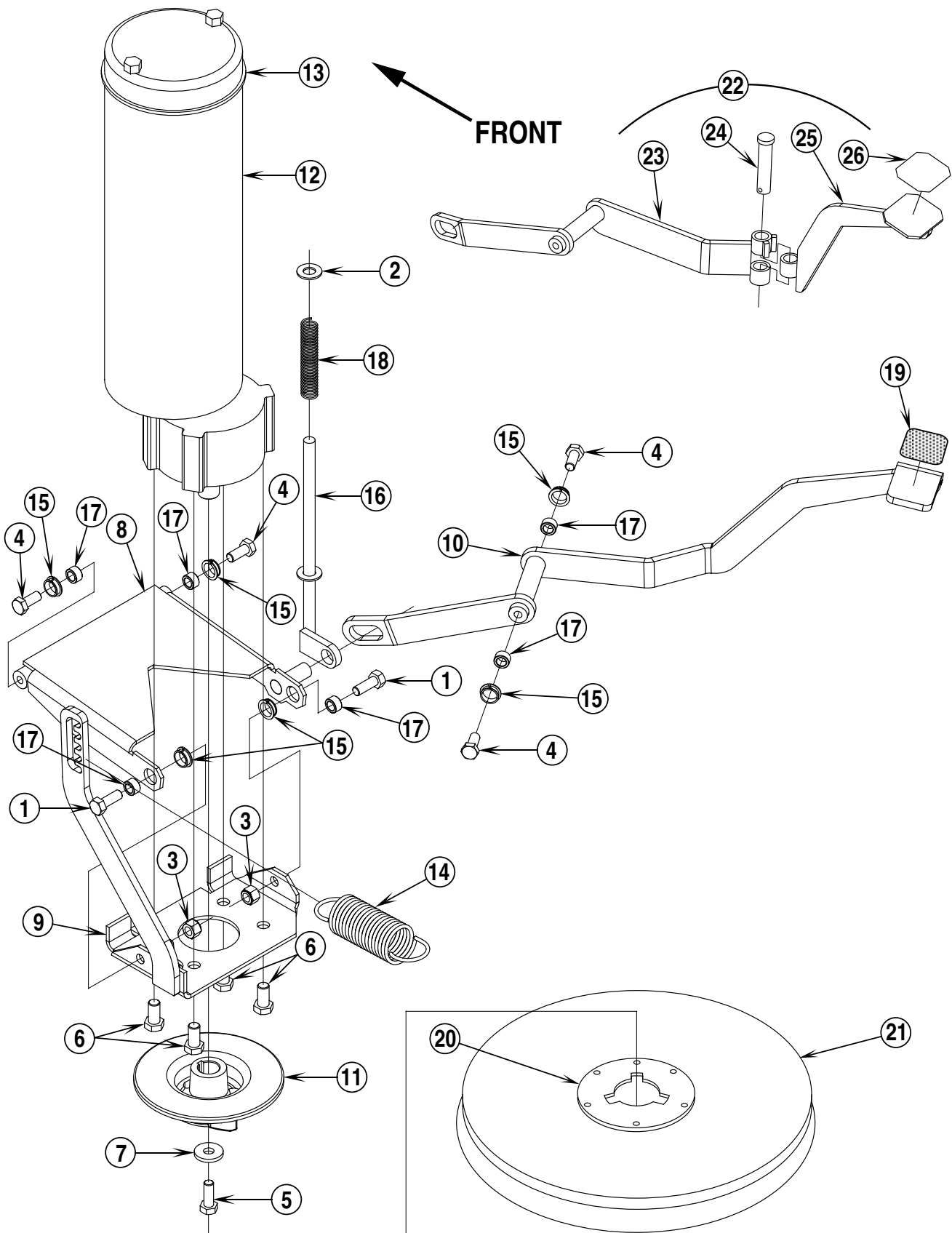

96-9	<b>BRUSH DRIVE SYSTEM</b>			
01-2	<b>Micromatic™ 17B</b>			<b>13</b>

Item	Ref. No.	Qty	Description
1	56002037	2	Scr, Hex Hd 5/16-18 x .88
2	56002063	1	Wsh, Flt SAE 3/8
3	56002701	2	Nut, Hex Nyl Loc 5/16-18
4	56002956	4	Scr, Hex Hd 5/16-18 x .75
5	56003335	1	Scr, Hex Loc SS 5/16-18 x .88
6	56003338	4	Scr, Hex Loc SS 3/8-16 x .75
7	56009122	1	Wsh, Flt .34 x .93 x .12
8	56302108	1	Linkage
9	56302112	1	Motor Mount
10	56302122	1	Lift Weldment ( <b>obsolete, order item #22 to replace</b> )
11	56302130	1	Drive Lug <b>TSB 682</b>
12	56302144	1	Brush Drive Motor
13	56302155	1	Gasket
14	56302160	1	Spring, Extension ( <b>spring hooks into second notch from bottom at both ends</b> )
15	56302164	6	Bearing, Flange
16	56302172	1	Rod
17	56320595	6	Bushing
18	56452141	1	Spring
19	56302173	1	Grip Surface
20	56506006	1	Clutch Plate, Universal
21	56505910	1	Short-Trim Pad Holder ( <b>optional</b> )
**	56505918	1	MidLite Grit™ 180 Brush (old style)
**	56505917	1	Mid Grit™ 240 Brush (old style)
**	56505913	1	AgLite™ 500 Brush (old style)
**	56505914	1	Prolene Brush (old style)
**	56505915	1	ProLite™ Brush (old style)
**	56505916	1	Union Mix Brush (old style)
**	56505270	1	Level-Set Pad Holder (old style)
22	56302321	1	Pedal Assembly (includes items 23-26) ( <b>after January 2000</b> )
23	56302325	1	Lower Pedal Weldment
24	56003620	1	Clevis Pin
25	56302314	1	Upper Pedal Weldment
26	56721255	1	Pad, Foot Pedal

\*\* = Optional

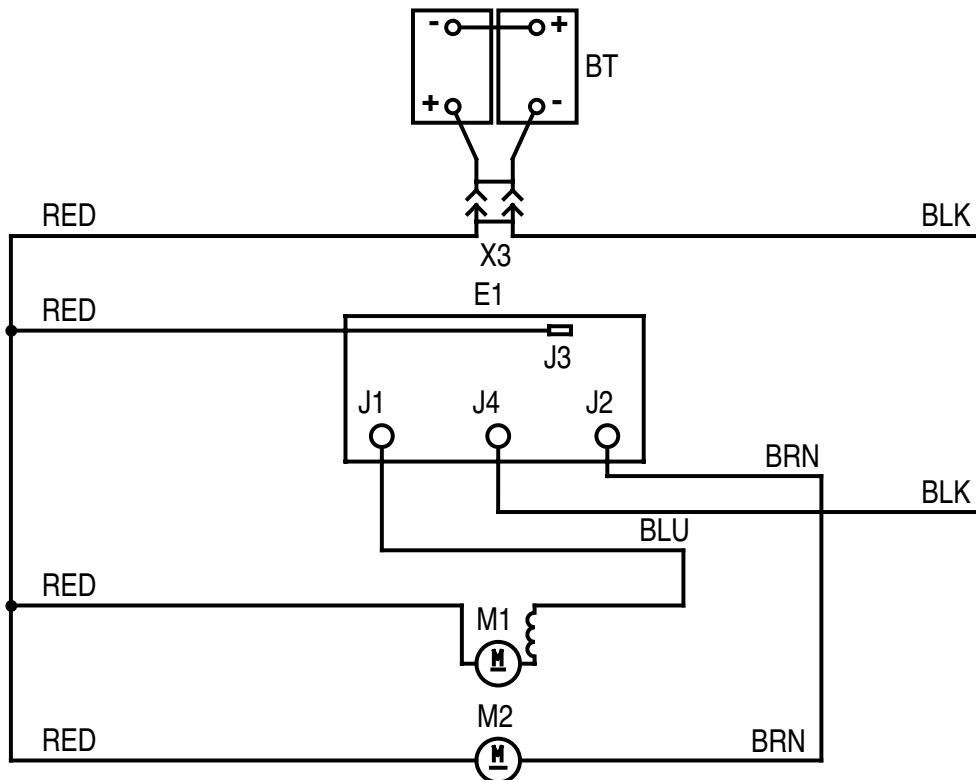
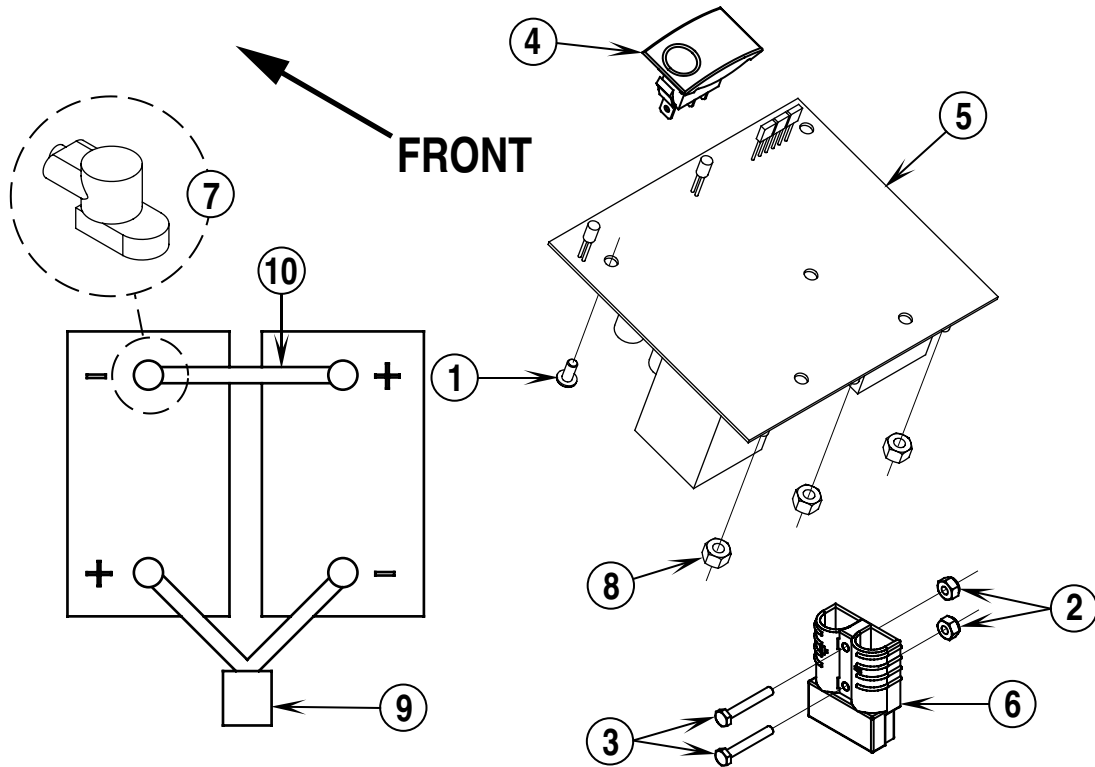

96-9	<b>ELECTRICAL SYSTEM / WIRING DIAGRAM</b>		
01-2	<b>Micromatic™ 17B</b>		<b>15</b>

Item	Ref. No.	Qty	Description
1	56001818	5	Scr, Pan Phil 8-32 x .38
2	56002830	2	Nut, Hex Nyl Loc 6-32
3	56003009	2	Scr, Hex Hd 6-32 x 1.00
4	56302156	1	Rocker Switch ( <b>Vac / Brush</b> )
5	56302185	1	Controller Assembly
6	56324305	1	Machine Battery Connector ( <b>part of Wiring Harness #302149</b> )
*	56302179	2	Replacement Contact for 56324305
7	56302194	4	Battery Terminal Cover
8	56002873	3	Nut, Hex Nyl Loc 10-32
9	56302174	1	Battery Charger Connector ( <b>w/cables</b> )
*	56302166	2	Replacement Contact for 56302174
10	56302225	1	Battery Cable
*	56302198	1	Optional Hour Meter Kit
*	56302196	1	Optional Battery Cart
*	56302149	1	Wiring Harness
*		1	Automatic Battery Charger 24V / 10A ( <b>not included</b> )
BT		A/R	Battery, 24V ( <b>not included</b> )
E1	56302185	1	Controller Assembly
M1	56324489	1	Vacuum Motor
*	56503003	1	Carbon Brush Set
M2	56302144	1	Brush Drive Motor
X3	56324305	1	Charger Connector
*	56302156	1	Rocker Switch ( <b>Vac / Brush, plugs into Controller Assembly #302185</b> )

\* = Not Shown



**Nilfisk  
Advance**  
*setting standards*

Nilfisk-Advance, Inc.  
14600 21st Avenue North  
Plymouth, MN, 55447-3408  
[www.nilfisk-advance.com](http://www.nilfisk-advance.com)  
Phone: 800-989-2235  
Fax: 800-989-6566  
©2001 Nilfisk-Advance, Inc.,  
Plymouth, MN 55447-3408  
Printed in the U.S.A.