



Electronic Service Manuals

This electronic document is provided as a service to our customers. We do not create the contents of the information contained in this document. Should you have detailed questions pertaining to the information contained in this document, you may contact Michco, or the manufacturer which provided the original information in this electronic deliverable. Michco's only part in this electronic deliverable was the electronic assembly process.

You may contact Michco through the following methods:
Phone (517) 484-9312 or (800) 331-3339 MI, OH, IN only
2011 N. High St. -- Lansing, Michigan -- 48906
Fax: (517) 484-9836
Email: CustServ@Michco.com
Web site: www.Michco.Com
Parts Web site: www.FloorMachineParts.Com

Order Parts on Line at:
www.FloorMachineParts.Com

Directly to Parts & Service:
By Email: **Shop@Michco.com**
By Fax: (517) 702-2041
By Voice: Use numbers above.

Serving the Cleaning Industry Since 1922

Notice: All copyrighted material remains property of original owners, all trademarks are property of respective owners. Manuals are subject to Manufacturer's reproduction limitations. Originals or reproductions were provided by manufacturers through a request. We make no warranty as to the correctness of information provided in this document and you assume all risk.

Convertamatic™ 32B / 32BD / 38BD

Hydro-Retriever™ 320BHD / 380BHD



PARTS LIST

**Advance MODELS 56395700(32B), 56395710(32BD)
56395720(38BD), 56395715(320BHD), 56395725(380BHD)**
All models covered in this manual are Obsolete.

This parts list is for machines after serial number 323354



Advance
by Nilfisk-Advance

TABLE OF CONTENTS

DESCRIPTION	PAGE
Handle Controls	1-2
Chassis	3-4
Skirts	5-6
Battery Housing	7-8
Squeegee Mount and Lift	9-10
Squeegee's	11-12
Solution Tank	13-14
Recovery Tank	15-16
Brush Drive Motor	17-18
Gear Case	19-20
Transport Drive	21-22
Differential and Brake	23-24
Wiring Diagram	25-26

WHEN ORDERING PARTS

- * Use the 8 digit numbers from the "Ref. No." columns in this parts list.
- * Specify the model and serial number of the machine.
- * Use the space below to record the model and serial number for future reference.

Model _____ Serial No. _____

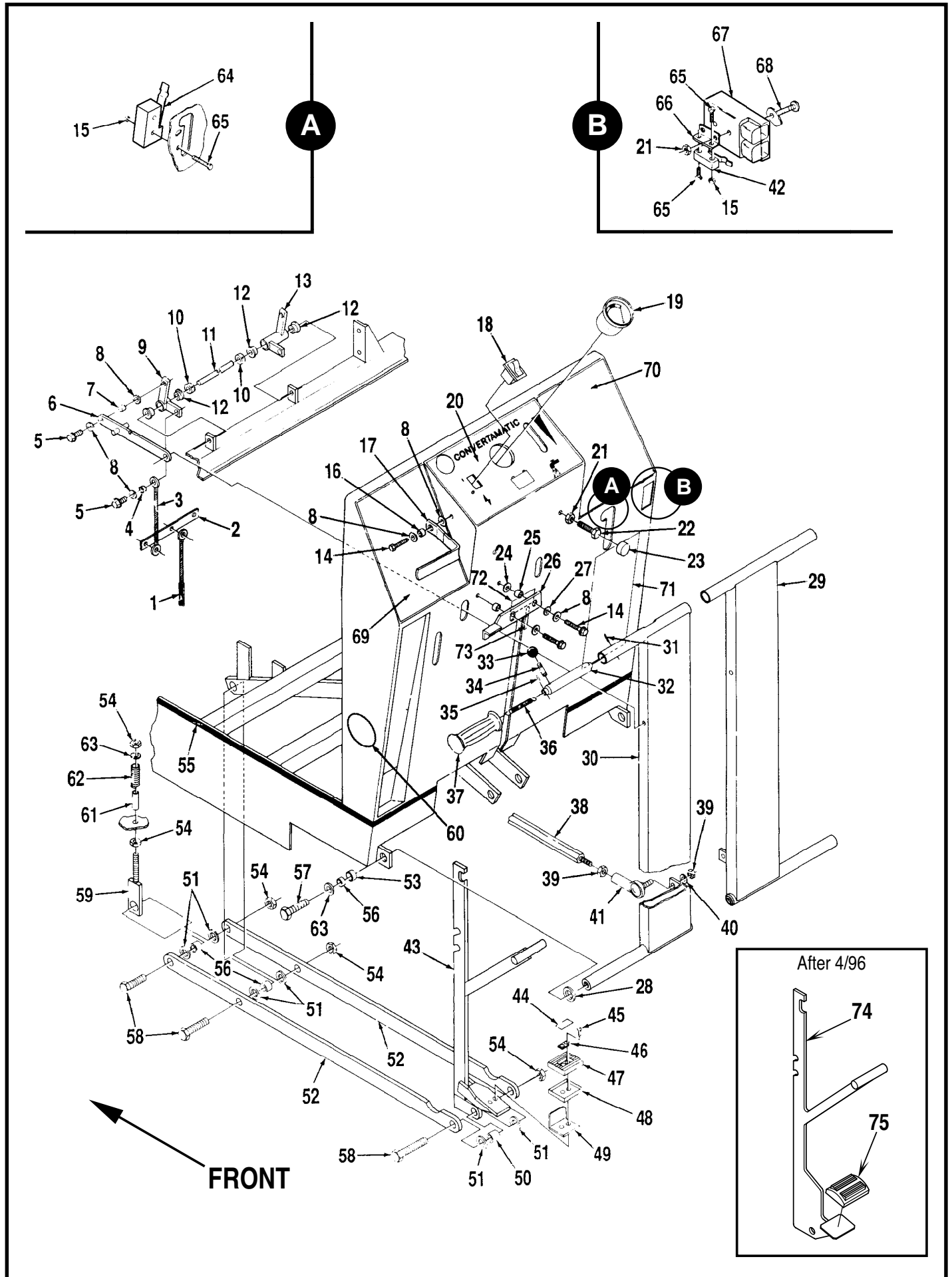

HANDLE CONTROLS

Item	Ref. No.	Qty	Description	Item	Ref. No.	Qty	Description
1	56395789	1	Cable	38	56395752	2	Control Rod
2	56395807	1	Bar	39	56002950	4	5/16-24 Ny-Loc Nut
3	56395747	2	Cable	40	56001939	4	5/16 Flat Washer
4	56328758	3	Bushing	41	56477756	2	Rod End
5	56001836	7	1/4-20 x 5/8 Screw	42	56376435	1	Charger Interlock Switch
6	56395816	2	Strap	43	56395787	1	Pedal Bracket (before 4/96)
7	56163872	4	Bushing	44	56016281	1	Decal, Brush (before 4/96)
8	56002098	14	1/4Flat Washer	45	56001832	2	Scr, Flt Hd 1/4-20 x 1 (before 4/96)
9	56395822	1	Collar	46	56365081	1	Plate (before 4/96)
10	56331076	2	Collar	47	56365086	1	Rubber Pad (before 4/96)
11	56395813	1	Shaft	48	56365087	1	Pedal Cup (before 4/96)
12	56491646	4	Bearing	49	56380255	1	Foot Guard (before 4/96)
13	56395823	1	Collar	50	56365030	1	Bushing
14	56002155	4	1/4-20 x 3/4 Screw	51	56367214	6	Washer
15	56002830	3	#6-32 Ny-Loc Nut	52	56378590	2	Arm
16	56368997	2	Bushing	53	56367168	4	Bearing
17	56395825	2	Handle	54	56002770	5	1/2-13 Ny-Loc Nut
18	56376348	1	Main Switch	55	56014043	10.5'	Decal, Stripe (3.25 m) 32B, 32BD, 38BD
19	56448677	1	Battery Meter	56	56367206	6	Bushing
20	56014464	1	Decal, Control Panel	57	56001831	4	1/2-13 x 1-1/4 Bolt
21	56002040	1	1/4-20 Jam Nut	58	56001995	3	1/2-13 x 1-3/4 Bolt
22	56386314	2	Leveler	59	56379786	1	Arm
23	56386316	2	Snap Cap	60	56014099	2	Decal, Logo
24	56151068	1	Fiber Washer	61	56372110	1	Bushing
25	56379298	2	Bushing	62	56372129	1	Spring
26	56395824	1	Latch	63	56001879	5	1/2 Flat Washer
27	56151041	1	Washer	64	56388019	1	Vacuum Motor Switch
28	56367192	4	Washer	65	56003009	4	#6-32 x 1 Screw
29	56395766	1	Right Handle	66	56389270	1	Bracket
	56395859	1	Left Handle Assembly (#30-37)	67	56395879	1	Charger Plug
30	56395767	1	Left Handle	68	56001833	2	1/4-20 x 1-1/2 Screw
31	56002291	1	1/8 x 1 Spring Pin	69	56014465	1	Decal, Control
32	56395769	1	Plunger	70	56014463	1	Decal, Instructions
33	56440817	1	Knob	71	56014504	1	Decal, Caution
34	56395763	1	Stud	72	56054195	1	Decal, Brush
35	56002560	1	1/8 x 1/2 Spring Pin	73	56055675	1	Decal, Pressure
36	56365769	1	Spring	74	56395145	1	Pedal Weldment (after 4/96)
37	56395884	2	Grip	75	56365002	1	Pedal, Rubber (after 4/96)
				*	56386058	1	Hanger Clip (for T-plug drain)

* = Not Shown

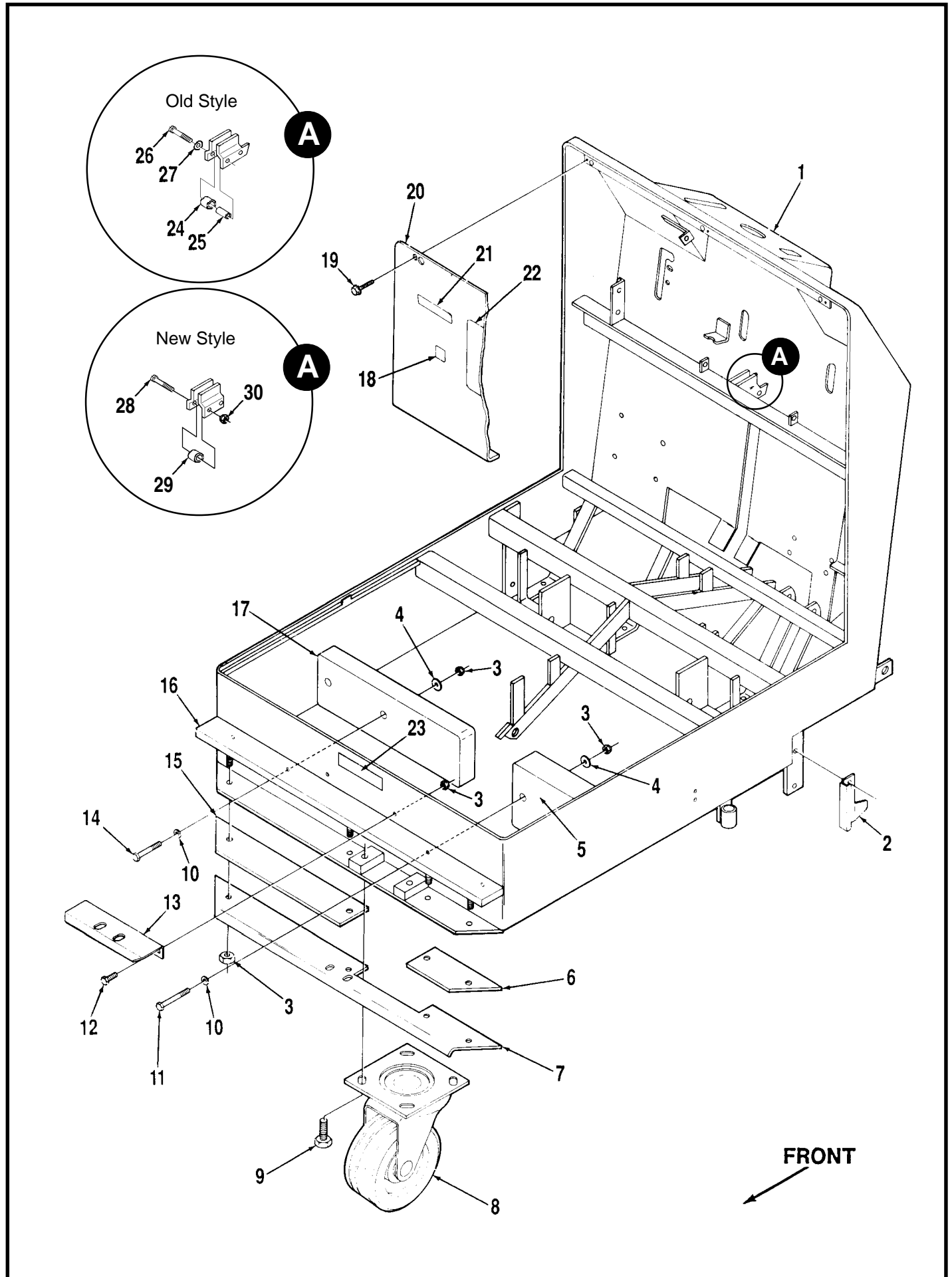

CHASSIS

Item	Ref. No.	Qty	Description
1	56395783	1	Chassis 32B, 32BD, 38BD
	56395885	1	Chassis 320 BHD, 380 BHD
2	56395784	1	Left Shield
*	56395785	1	Right Shield
3	56002708	10	1/4-20 Nyl Loc Nut
4	56454626	4	Washer
5	56395553	1	Left Weight Note #1
6	56395048	1	Plate
7	56402141	1	Plate
8	56365555	1	Caster
	56365742		Wheel for 56365555 Caster
9	56002663	4	3/8-16 x 1 Bolt
10	56002098	4	1/4 Flat Washer
11	56002603	2	1/4-20 x 3 Screw
12	56002093	2	1/4-20 x 1 Screw
13	56376578	1	Bracket Note #2
14	56001855	2	1/4-20 x 2-1/2 Screw
15	56395047	1	Plate
16	56395046	1	Cover Plate
17	56395552	1	Right Weight Note #1
18	56014625	1	Decal, Cable Routing
19	56002520	3	#10-24 x 1/2 Screw
20	56395868	1	Panel
21	56025363	1	Decal, Caution
22	56014469	1	Decal, Wiring
23	56016106	1	Decal, Caution
24	56365088	2	Bushing
25	56365089	2	Bushing
26	56002102	2	#10-24 X 1-1/4 Cap Screw
27	56001954	2	#10 Flat Washer
28	56002094	2	5/16-18 x 1-1/2 Bolt
29	56365088	2	Bushing
30	56002701	2	5/16-18 Nyl Loc Nut

* = Not Shown

Note #1 : Cast iron weights were added (after serial #489066) to reduce the tendency to lift the front caster wheel off the ground, when the drive is first engaged. If you are having this problem, order part number 56395555 Drive Engagement Kit.

Note #2 : This part is used only on the 320BHD, 380BHD and in the 32BD Heavy Duty Kit PN 56395985. The contents of the 32BD Heavy Duty Kit are listed below.

56395985 32BD Heavy Duty Kit

Ref. No.	Qty	Description
56395940	1	Right Skirt Assembly (see page 6)
56395930	1	Left Skirt Assembly (see page 6)
56395950	1	Squeegee Assembly (see page 12)
56376578	1	Bracket (see page 4)
56505782	2	Dyna Grit 80 Brush (see page 20)
56002708	2	1/4-20 Nyl Loc Nut (see page 4)
56002093	2	1/4-20 x 1 Screw (see page 4)

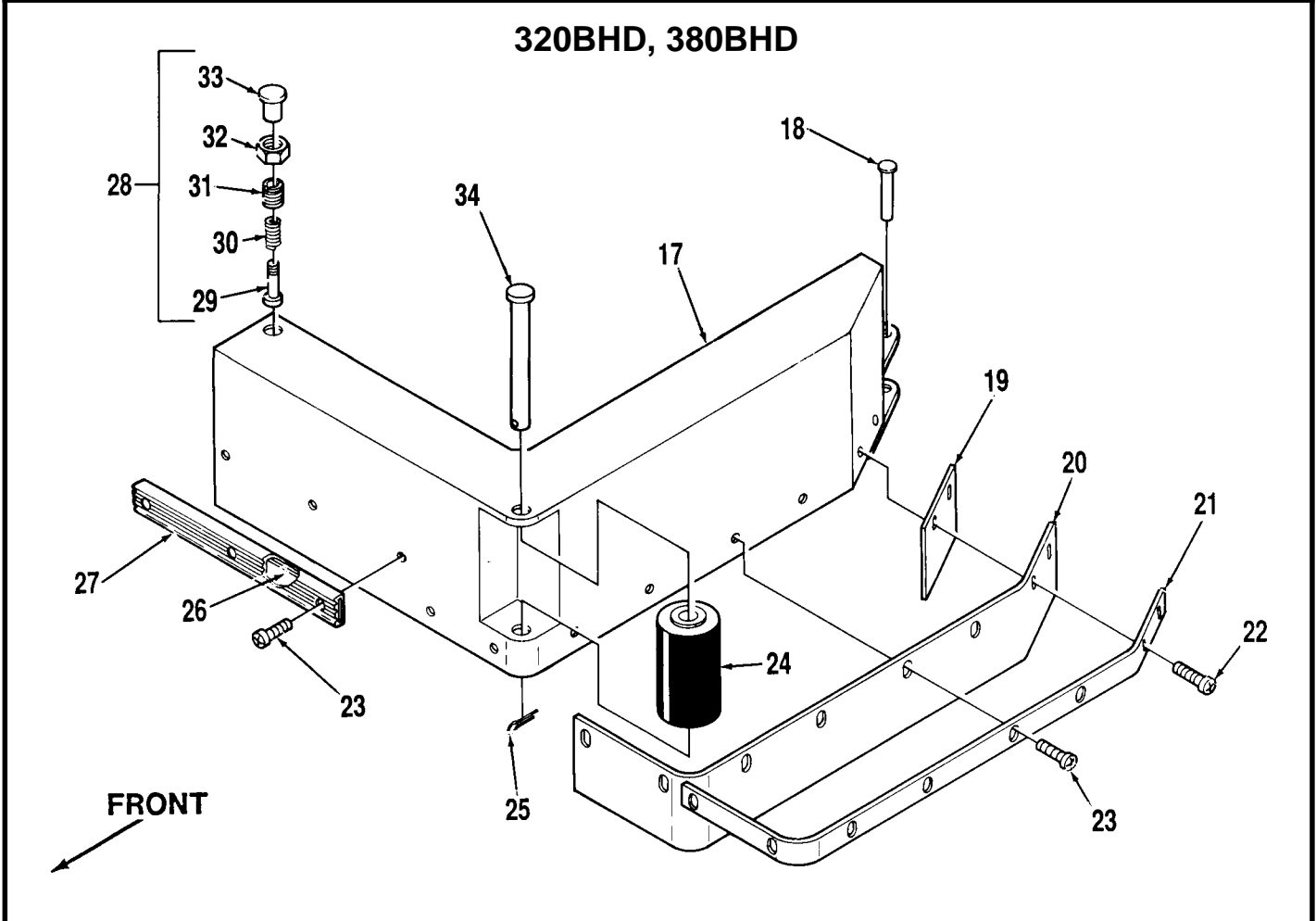
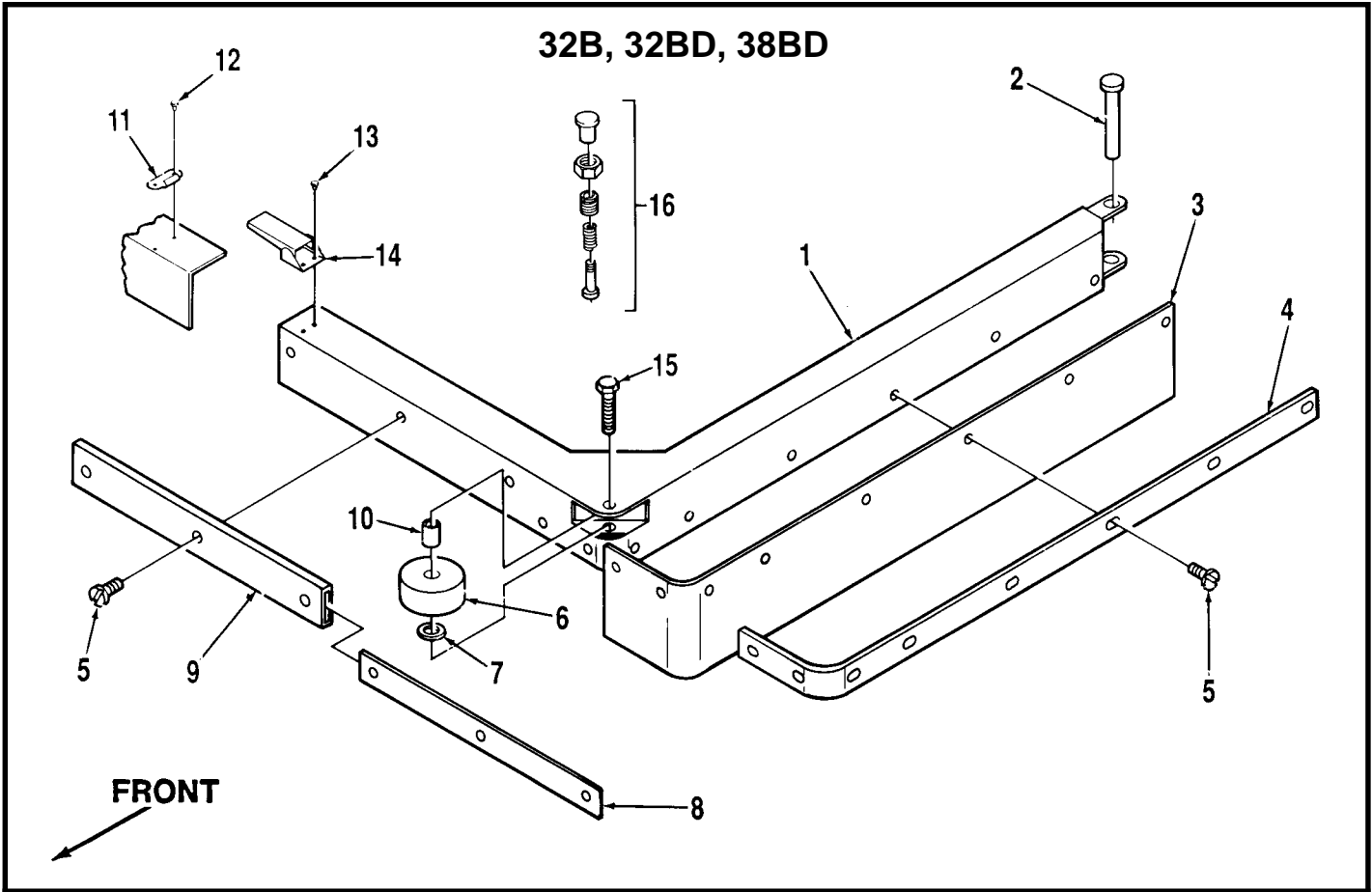

SKIRTS

Item	Ref. No.	Qty	Description	Item	Ref. No.	Qty	Description
	56395019	1	Left Skirt Assy 32B, 32BD (#1-15 ex 2,11,12)	56395930	1	Left Skirt Assy 320 BHD (#17-34) Note #2	
*	56395023	1	Right Skirt Assy 32B, 32BD (#1-15 ex 2,13,14)	*	56395940	1	Right Skirt Assy 320 BHD (#17-34) Note #2
	56395075	1	Left Skirt Assy 38BD (#1-15 ex 2,11,12)	56404126	1	Left Skirt Assy 380 BHD (#17-34)	
*	56395079	1	Right Skirt Assy 38BD (#1-15 ex 2,13,14)	*	56404118	1	Right Skirt Assy 380 BHD (#17-34)
1	56395021	1	Left Guard 32B, 32BD	17	56395943	1	Left Guard 320 BHD Note #2
*	56395025	1	Right Guard 32B, 32BD	*	56395929	1	Right Guard 320 BHD Note #2
	56395077	1	Left Guard 38BD		56404130	1	Left Guard 380 BHD
*	56395080	1	Right Guard 38BD Note #1	*	56404124	1	Right Guard 380 BHD
2	56360147	2	Brass Pin	18	56360147	2	Brass Pin
3	56381349	2	Skirt 32B, 32BD	19	56404215	2	Skirt (380 BHD only)
	56400289	2	Skirt 38BD	20	56395939	2	Skirt 320 BHD Note #2
4	56381330	2	Strap 32B, 32BD		56400289	2	Skirt 380 BHD
	56400262	2	Strap 38BD	21	56395935	2	Strap 320 BHD Note #2
5	56002717	20	#10-24 x 7/16 HP-5 Screw		56404220	2	Strap 380 BHD
6	56324350	2	Wheel 32B, 32BD	22	56404222	4	Screw (380 BHD only)
	56363855	2	Wheel 38BD	23	56372929	22	Screw (18 on 380 BHD)
7	56371009	2	Washer	24	56372740	2	Roller
8	56362107	2	Bumper Strap	25	56002529	2	Cotter Pin
9	56404122	2	Bumper	26	56362107	2	Bumper Strap
10	56360139	2	Bushing	27	56404122	2	Bumper
11	56342564	1	Plate	28	56578214	2	Lock Pin Assy (#28-32)
12	56900619	2	#8-32 x 1/4 HP-5 Screw	29	56578226	2	Pin
13	56003017	2	#6-32 x 1/4 HP-5 Screw	30	56578222	2	Spring
14	56471194	1	Latch	31	56578216	2	Socket
15	56002019	2	1/4-20 x 1-1/2 Screw	32	56578218	2	Nut
16	56365548	2	Pin Lock (old style, still available)	33	56362778	2	Knob
				34	56372882	2	Pin

* = Not Shown

Note #1 : Machines with bent and loose fitting brush skirts can be upgraded to a new hook latch. Order part number 56801026, Brush Skirt Latch Kit.

Note #2 : This part is used only on the 320BHD and in the 32BD Heavy Duty Kit PN 56395985.

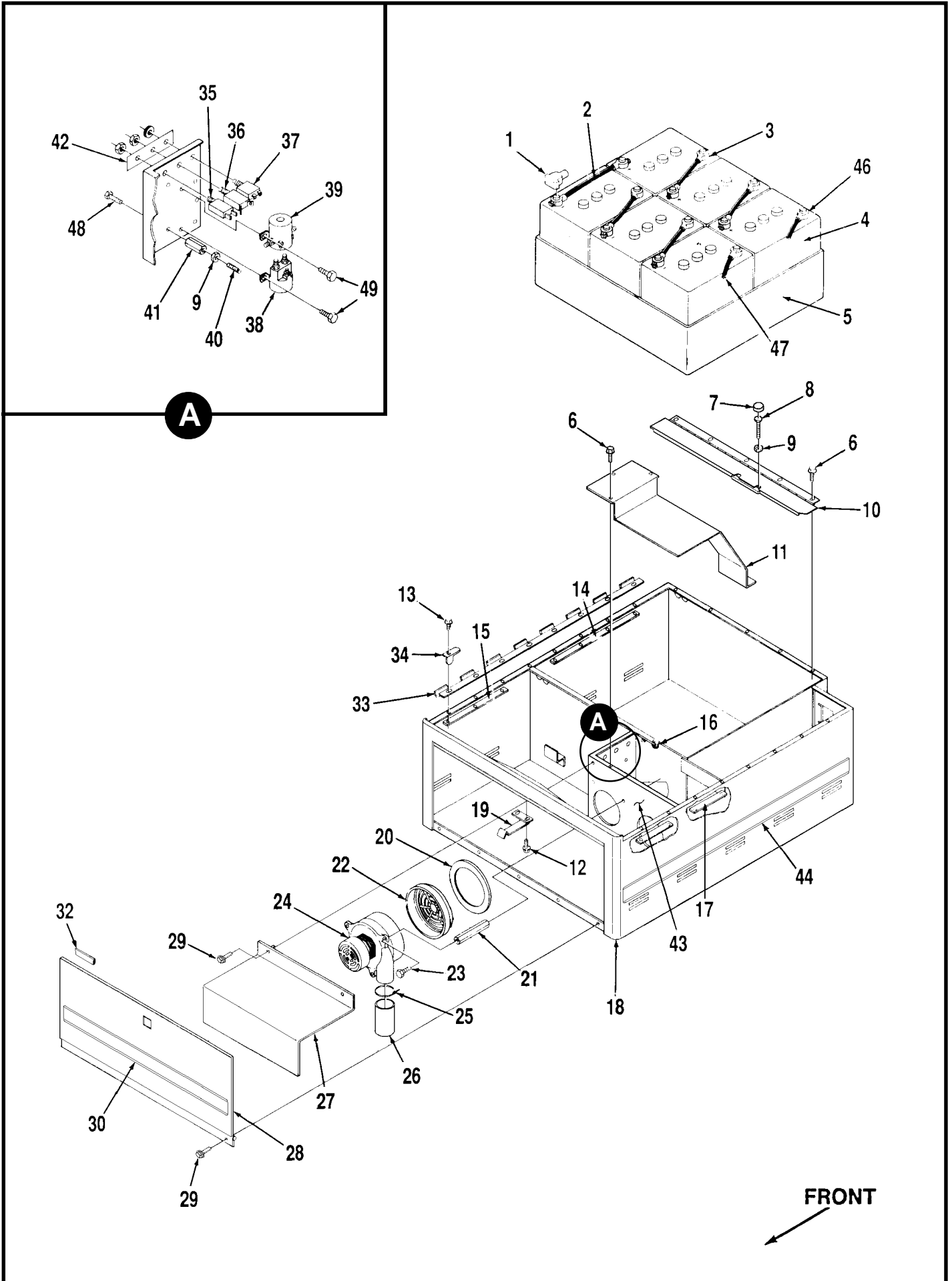

BATTERY HOUSING

Item	Ref. No.	Qty	Description	Item	Ref. No.	Qty	Description
1	56372673	12	Battery Terminal Boot	31			Omitted Intentionally
2	56363936	2	Battery Cable 15" TSB 730	32	56385248	3'	Gasket (93 cm)
3	56363928	3	Battery Cable 10" TSB 730	33	56381070	2	Hinge
4	56376014	6	244 AH 6V Battery (not included)	34	56381053	4	Hinge Clip
5	56395136	1	Battery Tray	35	56387316	1	Circuit Breaker 10A (control)
6	56002829	10	#10-24 x 5/8 Screw	36	56454423	1	Circuit Breaker 30A (vac)
7	56401788	4	Snap Cap	37	56454429	1	Circuit Breaker 70A (brush)
8	56401783	4	Leveler	38	56395450	1	Solenoid (brush)
9	56002040	6	1/4-20 Jam Nut	*	56389265	1	Diode
10	56395071	1	Cover	39	56395452	1	Solenoid (vac)
11	56395038	1	Belt Guard	*	56389265	1	Diode
12	56002519	2	#10-24 x 3/8 HP-5 Screw	40	56150274	2	Stud
13	56002503	16	#10-24 x 1/2 Screw	41	56469858	2	Stand-Off
14	56385414	2	Nut Plate	42	56016606	1	Decal, Circuit Breaker
15	56386286	1	Nut Plate	43	56395121	1	Plenum TSB 530, G-6
16	56740200	2	Strain Relief	44	56015543	1	Decal, Left 32B
17	56395206	2	Nut Plate	*	56015540	1	Decal, Right 32B
18	56395069	1	Battery Housing 32B, 32BD, 38BD		56015544	1	Decal, Left 32BD
	56395911	1	Battery Housing 320BHD, 380BHD	*	56015541	1	Decal, Right 32BD
19	56372700	1	Door Latch		56015545	1	Decal, Left 38BD
20	56385437	2	Gasket		* 56015542	1	Decal, Right 38BD
21	56395977	6	Stand-Off		56015557	2	Decal, Side 380BHD
22	56384898	2	Filter	45			Omitted Intentionally
23	56002689	6	1/4-20 x 3-1/2 Bolt	46	56395070	1	Battery Cable TSB 730
24	56395875	2	Vacuum Motor	47	56372524	1	Battery Cable TSB 730
	56395882	2	Vacuum Motor Assy	48	56002933	2	1/4-20 x 3/8 Screw
	56377001	1	Carbon Brush Set for Vac Motor	49	56001854	4	1/4-20 x 1/2 Screw
	56228051	2	Vac Motor Bearings				* = Not Shown
	56372588	2	Rotating Fan for Vac Motor				
25	56477613	2	Cable Tie				
26	56391807	2	Foam				
27	56395883	1	Shield				
28	56395031	1	Door 32B, 32BD, 38BD				
	56395914	1	Door 320BHD, 380BHD				
	56395029	1	Door Assy 32B, 32BD, 38BD				
	56395913	1	Door Assy 320BHD, 380BHD				
29	56002513	8	1/4-20 x 1/2 HP-5 Screw				
30	56015538	1	Decal, Front				

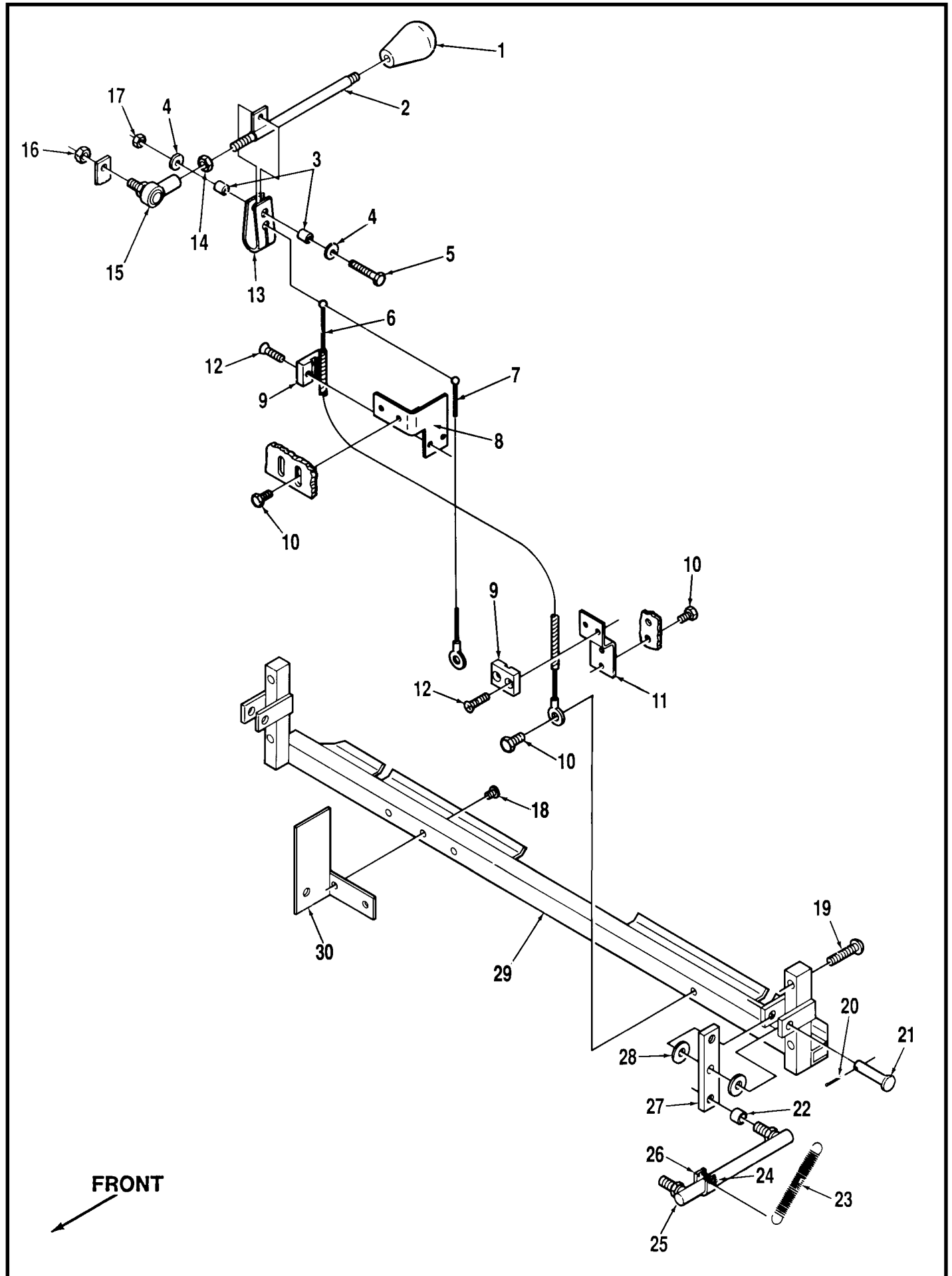

SQUEEGEE CONTROLS & MOUNT ASSEMBLY

Item	Ref. No.	Qty	Description
1	56364527	1	Knob
2	56395811	1	Rod
3	56475411	2	Bushing
4	56002098	2	1/4 Flat Washer
5	56001833	1	1/4-20 x 1-1/2 Screw
6	56395091	1	Cable Note #1
7	56395092	1	Cable Note #1
8	56395808	1	Bracket
9	56477884	2	Cable Clamp
10	56002530	6	1/4-20 x 3/8 HP-5 Screw
11	56395806	1	Bracket
12	56002517	4	1/4-20 x 3/4 HP-5 Flat Hd Screw
13	56395093	1	Pivot Note #1
14	56001884	1	5/16-24 Nut
15	56477756	1	Ball Joint
16	56002950	1	5/16-24 Nyl Loc Nut
17	56002708	1	1/4-20 Nyl Loc Nut
	56395858	1	Squeegee Mount Assy (#18-30)
18	56002518	2	#10-24 x 3/8 HP-5 Screw
19	56002019	4	1/4-20 x 1-1/2 Screw
20	56002363	2	1/16 x 5/8 Cotter Pin
21	56487989	2	Pin
22	56320595	4	Bushing
23	56395528	4	Spring
24	56002183	4	#4-40 x 7/8 Screw
*	56002746	4	#4-40 SS Nyl Loc Nut
25	56365289	4	Rod End
26	56395534	4	Collar
27	56395532	2	Bar
28	56150142	4	Washer
29	56379430	1	Squeegee Mount
30	56395502	1	Bracket

* = Not Shown

Note #1 : The old style cables (not shown) had eyelets at both ends. To replace, order part number 56395094 Squeegee Cable Kit (pivot yoke pn 56395093 included).

SQUEEGEES

Item	Ref. No.	Qty	Description	Item	Ref. No.	Qty	Description
	56395791	1	Squeegee Assembly 32B, 32BD (#1-16)		56395950	1	Squeegee Assembly 320 BHD (#17-31) Note #1
	56395797	1	Squeegee Assembly 38BD (#1-16)		56404050	1	Squeegee Assembly 380 BHD (#17-31)
1	56395792	1	Squeegee Tool 32B, 32BD	17	56395954	1	Squeegee Tool 320 BHD Note #1
	56395798	1	Squeegee Tool 38BD		56404056	1	Squeegee Tool 380 BHD
2	56370711	2	Thumb Nut	18	56370711	2	Thumb Nut
3	56001939	2	5/16 Flat Washer	19	56001939	2	5/16 Flat Washer
4	56400613	1	Gasket	20	56404019	2	Roller Assembly
5	56400614	2	Gasket	*	56404018	A/R	Bracket, Roller
	56395793	1	Squeegee Cartridge 32B, 32BD (#6-10,14)	*	56387017	A/R	Axle
	56395799	1	Squeegee Cartridge 38BD (#6-10,14)	*	56329554	A/R	Roller
				*	56290935	A/R	Nut, Push
6	56105560	1	Channel 32B, 32BD	21	56002486	4	#8-32 x 3/8 HP-5 Screw
	56105566	1	Channel 38BD	22	56395956	1	Rear Strap 320 BHD Note #1
7	56105538	2	Blade 32B, 32BD		56404062	1	Rear Strap 380 BHD
	56105543	2	Blade 38BD	23	56395952	1	Front Strap 320 BHD Note #1
8	56105561	1	Retainer 32B, 32BD		56404025	1	Front Strap 380 BHD
	56105567	1	Retainer 38BD	24	56001954	20	#10 Flat Washer (22 on 380 BHD)
9	56003037	2	1/4-20 x 1/4 Stnlss Stl Screw	25	56002011	20	#10 Shakeproof Washer (22 on 380 BHD)
10	56900274	2	1/4-20 x 1 Stnlss Stl Screw	26	56209491	20	#10-24 x 5/8 SS Screw (22 on 380 BHD)
11	56371009	4	Washer	27	56377766	2	Angle
12	56157060	2	Retainer Ring	28	56395963	1	Oil Resistant Blade Kit 320 BHD
13	56324499	2	Wheel		56395964	1	Gum Rubber Blade Kit 320 BHD
14	56201677	2	1/4-20 Locking Wing Nut		56404024	1	Oil Resistant Blade Kit 380 BHD
15	56002098	2	1/4 Flat Washer		56404023	1	Gum Rubber Blade Kit 380 BHD
16	56387376	2	Roller	29	56371009	4	Washer
				30	56157060	2	Retainer Ring
				31	56324499	2	Wheel

* = Not Shown

Note #1: This part is used only on the 320BHD and in the 32BD Heavy Duty Kit PN 56395985.

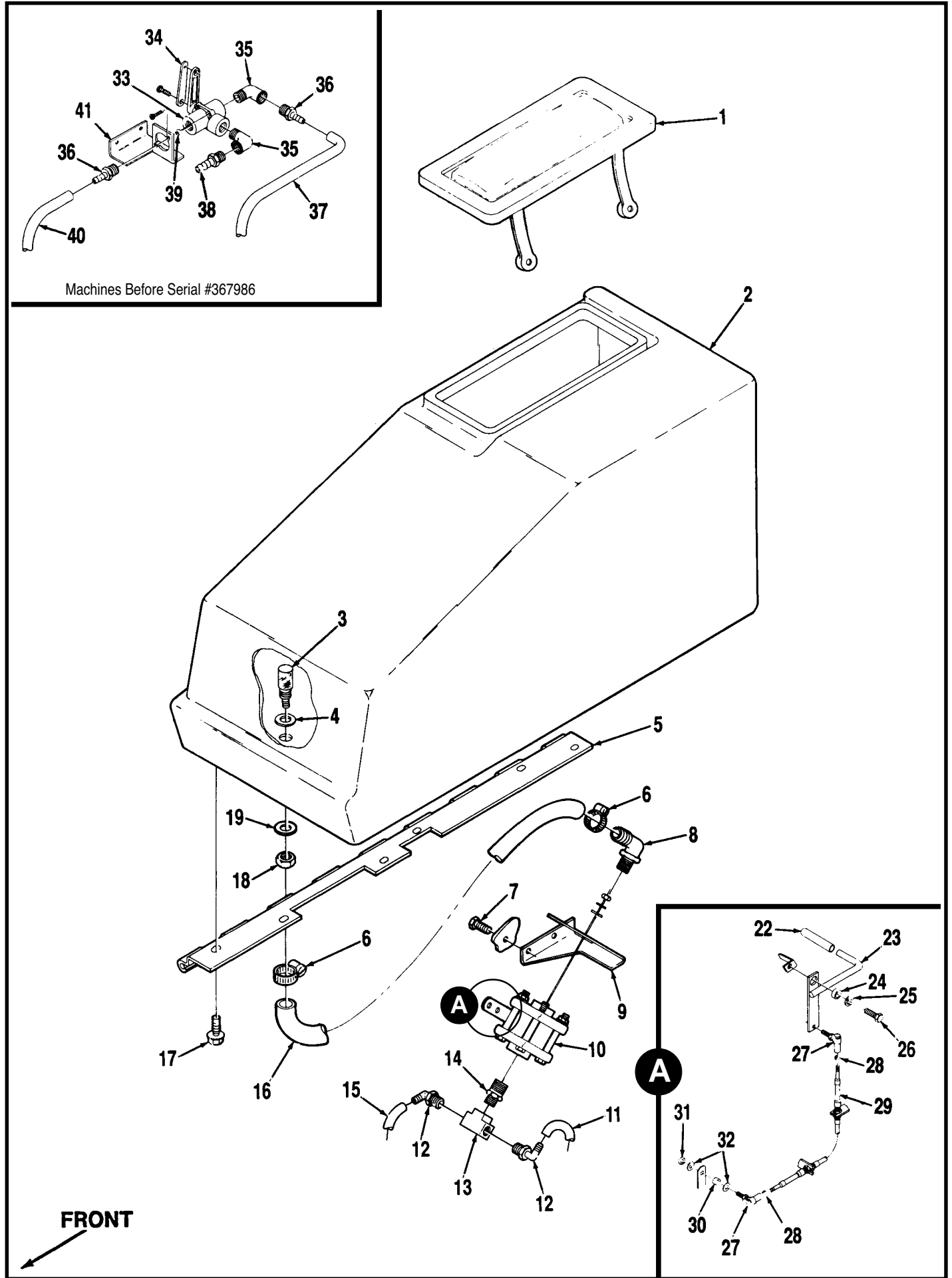

SOLUTION SYSTEM

Item	Ref. No.	Qty	Description	Item	Ref. No.	Qty	Description
1	56395916	1	Cover Assembly	20			Omitted Intentionally
	56261381	1	Cover	21			Omitted Intentionally
	56263379	2	Strap	22	56376486	1	Cap
2	56395847	1	Solution Tank	23	56395829	1	Lever
3	56395909	1	Screen	24	56185263	1	Bushing
4	56368776	1	Rubber Washer	25	56002220	1	5/16 Flat Washer
5	56404529	1	Hinge	26	56002037	1	5/16-18 X 7/8 Bolt
6	56219932	2	Hose Clamp	27	56488290	2	Ball Joint
7	56002513	2	1/4-20 X 1/2 HP-5 Screw	28	56002040	2	1/4-20 Jam Nut
8	56391678	1	Barb	29	56395877	1	Cable
	56395965	1	Solution Valve Assembly (#9-15)	30	56163872	1	Bushing
9	56395966	1	Valve Mount	31	56002708	1	1/4-20 Nyl-Lock Nut
10	56391686	1	Solution Valve TSB 553, G-3	32	56001906	2	1/4 Flat Washer
			TSB 500, G-8	33	56454612	1	Solution Valve TSB 553, G-3
11	56391802	1	Solution Hose 29"				TSB 500, G-8
12	56900035	2	Barb	34	56391836	1	Strap
13	56900291	1	Tee	35	56742125	2	Elbow
14	56900639	1	Nipple	36	56749202	2	Barb
15	56456830	1	Solution Hose 10"	37	56395843	1	Tube
16	56395870	1	Solution Hose	38	56118117	1	Barb
17	56001861	6	1/4-20 X 3/8 Screw	39	56200123	2	Bushing
18	56002847	1	5/8-11 Nut	40	56395869	1	Tube
19	56263381	1	Brass Washer	41	56395830	1	Valve Mount

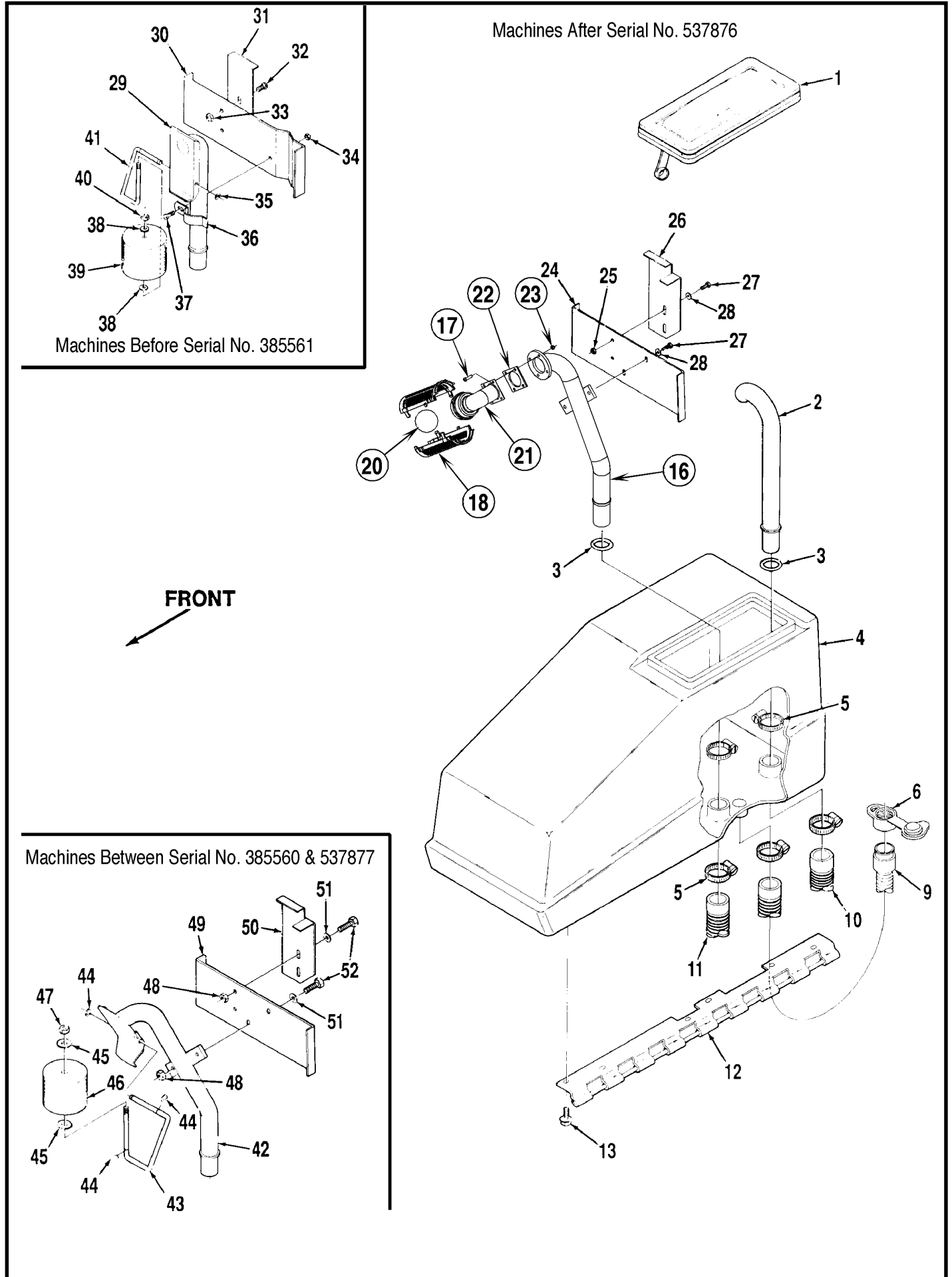

RECOVERY SYSTEM

Item	Ref. No.	Qty	Description	Item	Ref. No.	Qty	Description
1	56261393	1	Cover Assembly	26	56395903	1	Support Note #2
	56261395	1	Cover	27	56002807	4	1/4-20 X 3/4 Stnlss Stl Screw
	56261398	1	Gaske TSB 532, G-5	28	56002859	4	1/4 Stnlss Stl Flat Washer
	56263379	2	Strap	29	56395853	1	Float Tube Note #1
2	56395849	1	Tube	30	56395902	1	Baffle
3	56900098	2	O-Ring	31	56395903	1	Support
4	56395845	1	Recovery Tank	32	56002723	2	1/4-20 X 3/4 Brass Screw
5	56440213	5	Hose Clamp	33	56002718	2	1/4-20 Brass Nut
6	56324180	1	Drain Plug	34	56002836	1	#10-24 Stnlss Stl Nut
*	56324349	1	Hook	35	56321125	3	Retainer Ring
7			Intentionally Omitted	36	56376493	1	Clamp
8			Intentionally Omitted	37	56209489	1	#10-24 X 1 Screw
9	56395865	1	Drain Hose	38	56150142	2	Flat Washer
10	56379208	1	Squeegee Hose	39	56385198	1	Float
11	56365626	1	Vacuum Motor Hose	40	56150975	1	Lock Nut
12	56404529	1	Hinge	41	56391723	1	Float Rod Note #1
13	56001861	6	1/4-20 X 3/8 Screw	42	56395959	1	Float Tube Note #1
14			Omitted Intentionally	43	56395961	1	Float Rod Note #1
15			Omitted Intentionally	44	56321125	3	Retainer Ring
16	56395975	1	Float Tube	45	56454626	2	Flat Washer
17	56002894	4	Scr, Pan Phil SS 10-24 x .75	46	56385349	1	Float
18	56324497	2	Float Cage	47	56150975	1	Lock Nut
19			Omitted Intentionally	48	56002718	4	1/4-20 Brass Nut
20	56391690	1	Float Ball	49	56395960	1	Baffle
21	56324012	1	Float Elbow	50	56395903	1	Support
22	56391644	1	Gasket	51	56002536	4	1/4 Brass Flat Washer
23	56002836	4	#10-24 Stnlss Stl Nut	52	56002723	4	1/4-20 X 3/4 Brass Screw
24	56395960	1	Baffle				
25	56002491	2	1/4-20 Stnlss Stl Nut				* = Not Shown

Note #1 : Obsolete part numbers, to replace, order part number 56395200 Float Kit (includes #3, 16-28).

Note #2 : Support brace used on machines after serial #371508. Add to earlier model machines to improve vacuum cover seal.

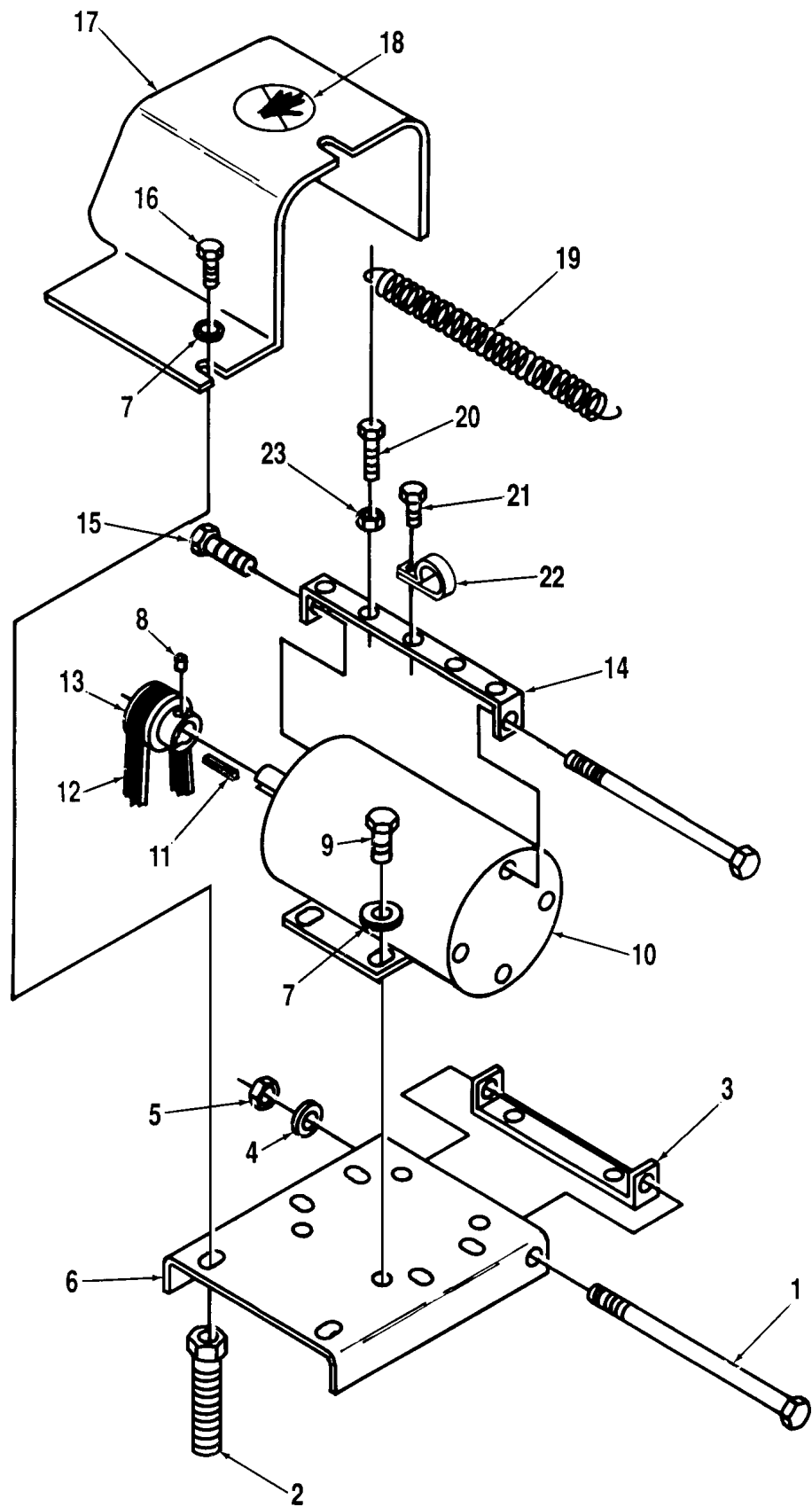

FRONT
↙

BRUSH DRIVE MOTOR

Item	Ref. No.	Qty	Description
1	56378692	1	Bolt
2	56378631	2	Adjustment Screw
3	56395044	1	Mount Bracket
4	56002063	1	3/8 Flat Washer
5	56002769	1	3/8-16 Nyl Loc Nut
6	56395007	1	Mounting Plate
7	56001939	5	5/16 Flat Washer
8	56001826	2	5/16-18 x 1/2 Set Screw
9	56002667	4	5/16-18 x 3/4 Bolt
10	56454454	1	Brush Drive Motor
	56448729	1	Carbon Brush Set for Motor
11	56443719	1	3/16 x 1-5/16 Key
12	56378853	1	Belt 32B, 32BD, 320BHD
	56378852	1	Belt 38BD, 380BHD
13	56379730	1	Sheave 32B, 32BD, 320BHD
	56379736	1	Sheave 38BD, 380BHD
14	56379732	1	Bracket
15	56002933	1	1/4-20 x 3/8 Screw
16	56001862	1	5/16-18 x 1/2 Bolt
17	56395073	1	Belt Guard (fits all machines)
18	56030080	1	Decal, Hands Clear
19	56371114	1	Spring
20	56001833	1	1/4-20 x 1-1/2 Screw
21	56001854	2	1/4-20 x 1/2 Screw
22	56328064	1	Clamp
23	56002040	1	1/4-20 Jam Nut

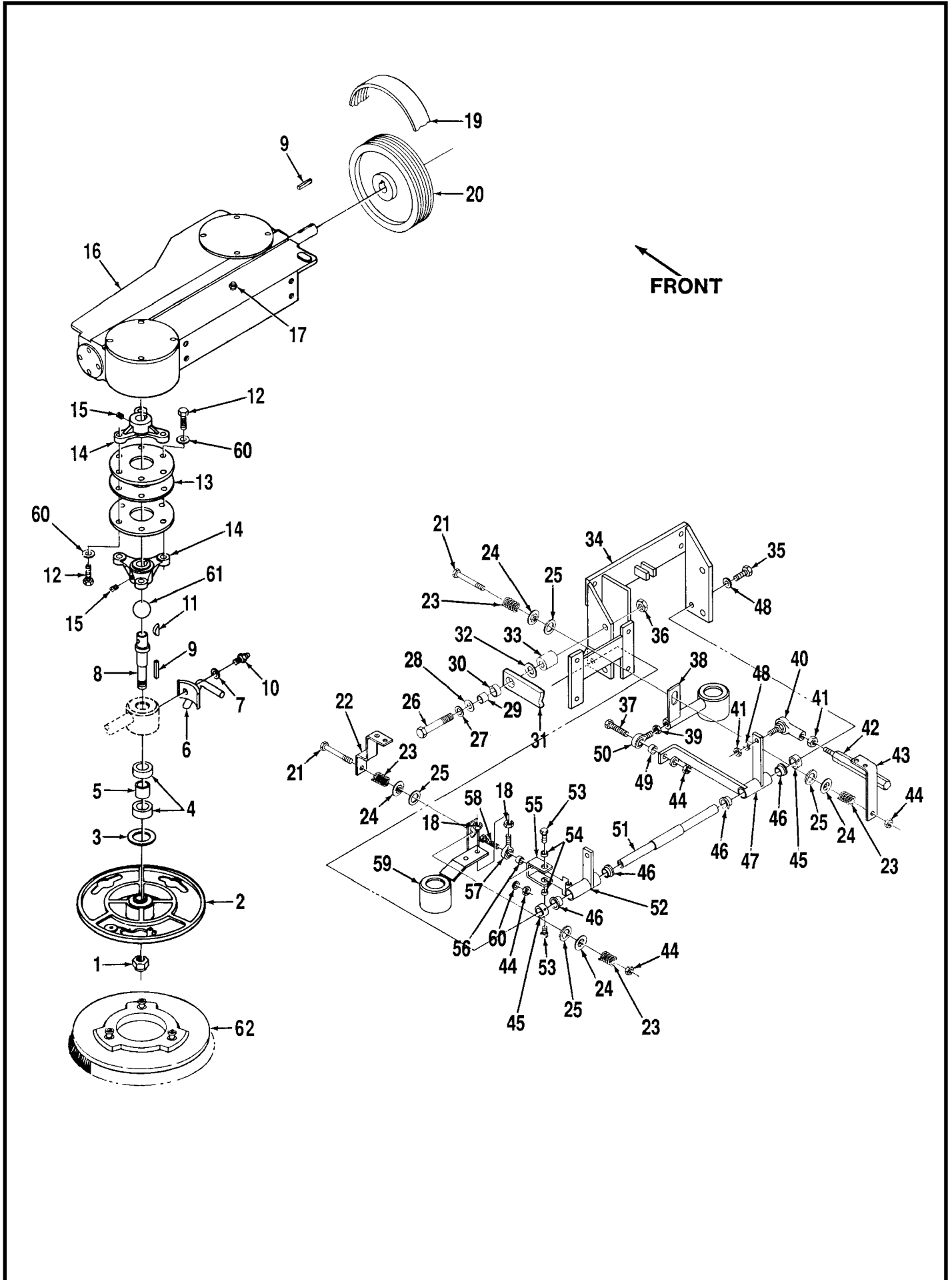

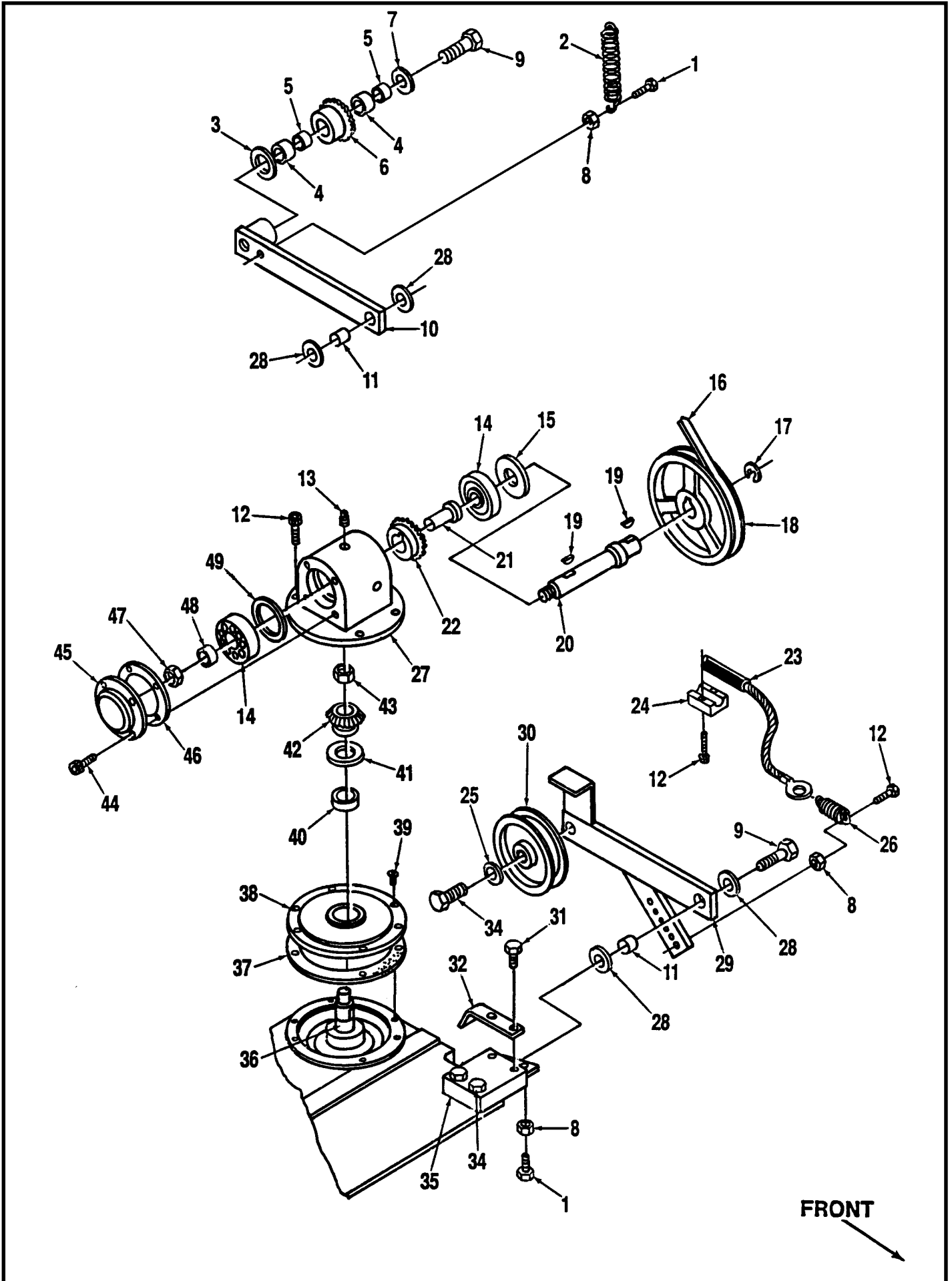

TRANSPORT DRIVE

Item	Ref. No.	Qty	Description	Item	Ref. No.	Qty	Description
1	56002155	2	1/4-20 x 3/4 Screw	28	56002168	4	1/2 Flat Washer
2	56370746	1	Spring	29	56390720	1	Tension Arm
3	56367184	1	Washer	30	56390682	1	Pulley
4	56367168	2	Bearing	31	56001854	2	1/4-20 x 1/2 Screw
5	56367206	2	Bushing	32	56390828	1	Belt Guide
6	56390992	1	Sprocket	33			Omitted Intentionally
7	56367214	5	Washer	34	56002095	3	3/8-16 x 1 1/2 Bolt
8	56002040	3	1/4-20 Jam Nut	35	56390704	1	Mounting Block
9	56001920	2	1/2-13 x 2-1/4 Bolt	36	56444650	1	Shaft
10	56390933	1	Idler Arm	37	56366684	A/R	Red Shim
11	56360627	2	Bushing		56366692	A/R	Blue Shim
12	56002093	6	1/4-20 x 1 Screw		56366706	A/R	Pink Shim
13	56366269	1	Plug	38	56444693	1	Cap
14	56108537	2	Ball Bearing	39	56002755	2	1/4-20 x 1/2 Flat Head Screw
15	56444723	1	Grease Seal	40	56378275	1	Grease Seal
16	56465430	1	Belt	41	56444839	1	Shim
17	56478775	1	Retaining Ring	42	56109088	1	Gear
18	56344044	1	Sheave	43	56002708	1	1/4-20 Ny-Loc Nut
19	56154083	2	Key	44	56001836	4	1/4-20 x 5/8 Screw
20	56391042	1	Shaft	45	56444715	1	End Cap
21	56444707	1	Spacer	46	56378488	A/R	Red Shim
22	56109088	1	Gear		56378496	A/R	Blue Shim
23	56395789	1	Cable		56378518	A/R	Pink Shim
24	56477884	2	Cable Clamp	47	56002952	1	9/16-18 Ny-Loc Nut
25	56002055	1	3/8 Flat Washer	48	56444677	1	Spacer
26	56112054	1	Spring	49	56444731	1	Retaining Ring
27	56444634	1	Housing				

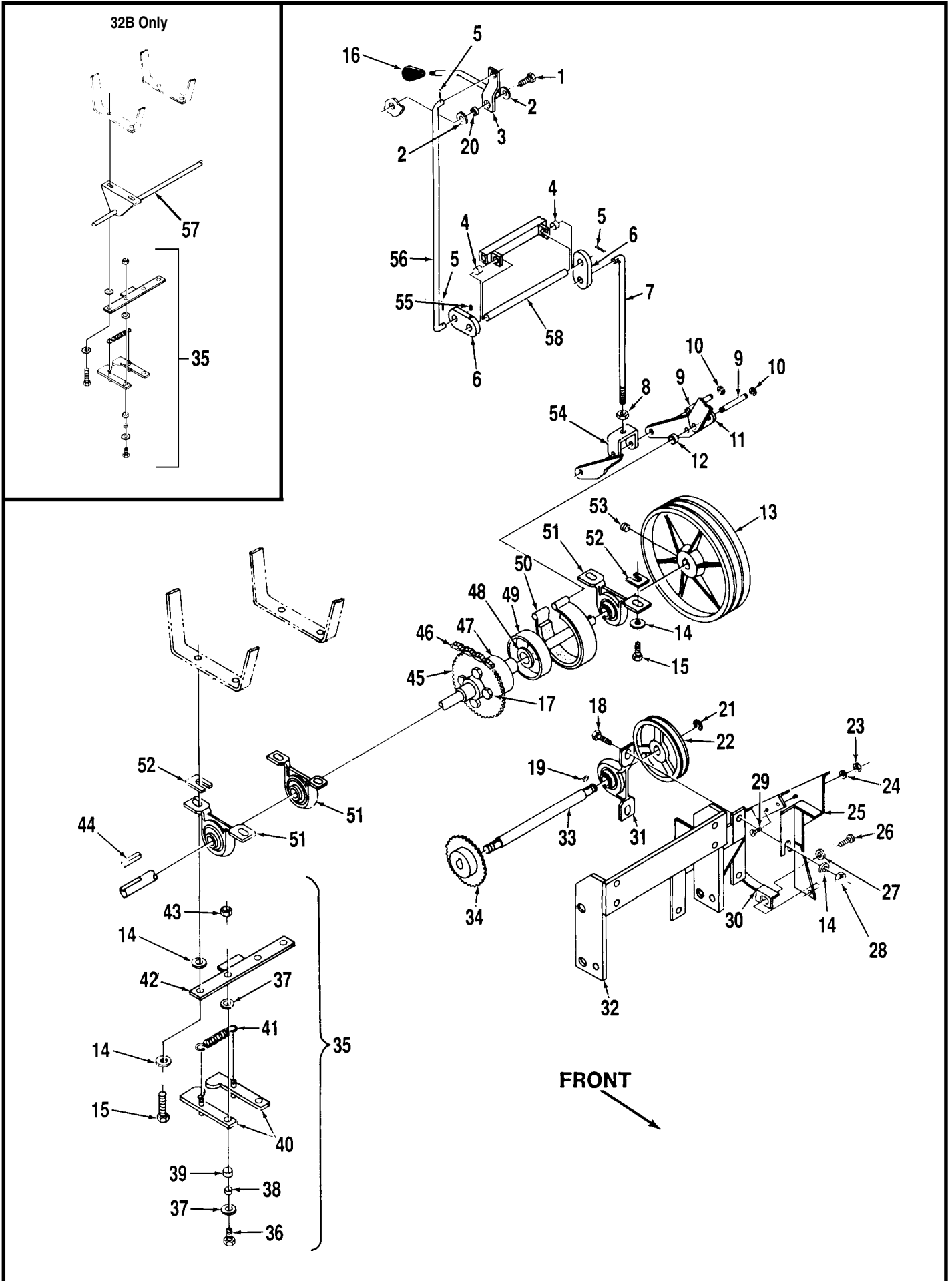

DIFFERENTIAL AND BRAKE

Item	Ref. No.	Qty	Description	Item	Ref. No.	Qty	Description
1	56001895	1	1/2-13 x 1 Bolt	32	56395734	1	Bracket 32B
2	56367214	2	Washer		56395733	1	Bracket 32BD, 320BHD
3	56402844	1	Brake Lever		56395732	1	Bracket 38BD, 380BHD
4	56370754	2	Bearing	33	56391123	1	Shaft 32BD, 320BHD
5	56002363	3	1/16 X 5/8 Cotter Pin		56403199	1	Shaft 38BD, 380BHD
6	56402922	2	Plate	34	56391182	1	Sprocket
7	56395803	1	Lower Rod	35	56395857	1	Centering Assembly (#36-43)
8	56002040	1	1/4-20 Jam Nut	36	56002093	2	1/4-20 x 1 Screw
9	56402995	3	Pin	37	56150142	2	Washer
10	56321427	6	Retaining Ring	38	56453849	2	Bushing
11	56402990	2	Arm	39	56368970	2	Bearing
12	56328022	2	Bushing	40	56395790	2	Arm
13	56395233	2	Green Urethane Wheel (std)	41	56395530	2	Spring
	56395240	2	Gray Non-Marking Wheel (opt) 32BD, 38BD, 320BHD, 380BHD	42	56395510	1	Bar
*	56395222	2	Wheel 32B only	43	56002708	2	1/4-20 Ny-Loc Nut
14	56002055	14	3/8 Flat Washer	44	56340863	2	Key
15	56002127	10	3/8-16 x 3/4 Bolt	45	56395252	1	Sprocket (before 3/95 - TSB 801)
16	56364527	1	Knob		56395253	1	Sprocket (after 2/95 - TSB 801)
17	56468033	4	5/16-18 x 4-1/2 Bolt	46	56395871	1	Chain
18	56002663	4	3/8-16 x 1 Bolt	*	56468839	1	Master Link
19	56003227	2	Key	*	56468837	1	Offset Link
20	56365030	1	Bushing	47	56395250	1	Differential (before 3/95 - TSB 801)
21	56478775	2	Retaining Ring		56395251	1	Differential (after 2/95 - TSB 801)
22	56344044	1	Sheave	48	56469012	1	Spacer
23	56002768	2	#10-24 Ny-Loc Nut	49	56469026	1	Brake Drum
24	56002053	2	#10 Flat Washer	50	56402745	1	Brake Strap
25	56390623	1	Belt Guide	51	56444308	4	Pillow Block
26	56001854	1	1/4-20 x 1/2 Screw	*	56101753		Grease Zert for PN 56444308
27	56001906	1	1/4 Flat Washer	52	56390925	A/R	Shim
28	56002769	4	3/8-16 Ny-Loc Nut	53	56001826	2	5/16-18 x 1/2 Set Screw
29	56002503	2	#10-24 x 1/2 Screw	54	56402971	1	Bracket
30	56390887	1	Belt Guide	55	56002930	2	1/4-20 x 3/8 Set Screw
31	56494506	2	Pillow Block	56	56395804	1	Upper Rod
				57	56395040	1	Axle 32B
				58	56395362	1	Rod

* = Not Shown

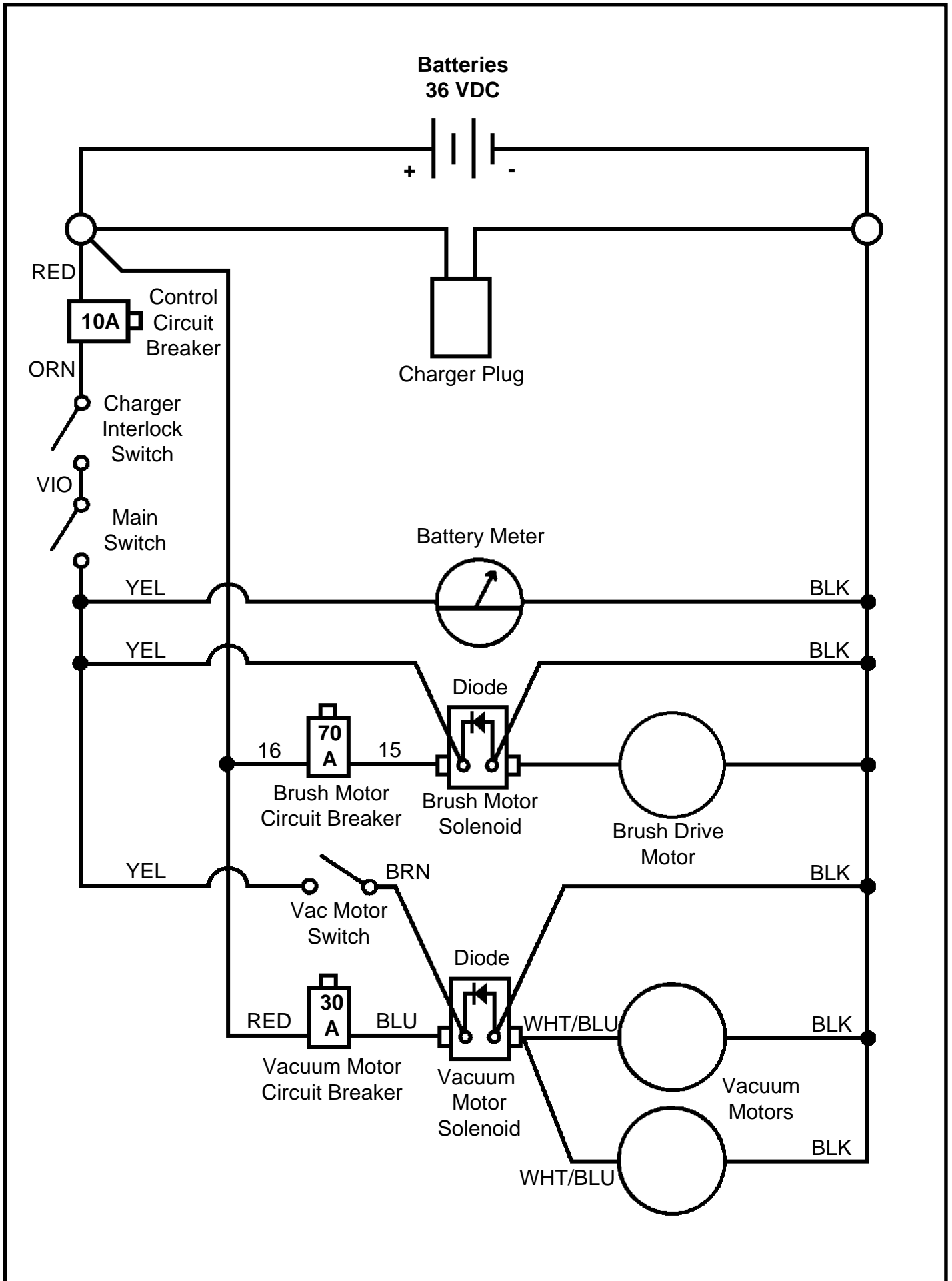

WIRING DIAGRAM

Ref. No.	Qty	Description
** 56376014	6	Battery 244 Amp Hour
56395879	1	Charger Plug
56387316	1	Circuit Breaker 10 Amp, Control Circuit
56376435	1	Charger Interlock Switch
56376348	1	Main Switch
56448677	1	Battery Meter
56454454	1	Brush Drive Motor
56448729	1	Carbon Brush Set For 56454454 Brush Motor
56395450	1	Brush Motor Solenoid
56389265	1	Diode
56454429	1	Circuit Breaker 70 Amp, Brush Motor
56388019	1	Vacuum Motor Switch
56395875	2	Vacuum Motor
56377001	1	Carbon Brush Set For 56395875 Vacuum Motor
56395452	1	Vacuum Motor Solenoid
56389265	1	Diode
56454423	1	Circuit Breaker 30 Amp, Vacuum Motor

** = Not Included



Nilfisk-Advance, Inc.
14600 21st Avenue North
Plymouth, MN, 55447-3408
www.nilfisk-advance.com
Phone: 800-989-2235
Fax: 800-989-6566
©2000 Nilfisk-Advance, Inc.,
Plymouth, MN 55447-3408
Printed in the U.S.A.