



## Electronic Service Manuals

This electronic document is provided as a service to our customers. We do not create the contents of the information contained in this document. Should you have detailed questions pertaining to the information contained in this document, you may contact Michco, or the manufacturer which provided the original information in this electronic deliverable. Michco's only part in this electronic deliverable was the electronic assembly process.

You may contact Michco through the following methods:  
Phone (517) 484-9312 or (800) 331-3339 MI, OH, IN only  
2011 N. High St. -- Lansing, Michigan -- 48906  
Fax: (517) 484-9836  
Email: [CustServ@Michco.com](mailto:CustServ@Michco.com)  
Web site: [www.Michco.Com](http://www.Michco.Com)  
Parts Web site: [www.FloorMachineParts.Com](http://www.FloorMachineParts.Com)

Order Parts on Line at:  
**[www.FloorMachineParts.Com](http://www.FloorMachineParts.Com)**

Directly to Parts & Service:  
By Email: **[Shop@Michco.com](mailto:Shop@Michco.com)**  
By Fax: (517) 702-2041  
By Voice: Use numbers above.

**Serving the Cleaning Industry Since 1922**

Notice: All copyrighted material remains property of original owners, all trademarks are property of respective owners. Manuals are subject to Manufacturer's reproduction limitations. Originals or reproductions were provided by manufacturers through a request. We make no warranty as to the correctness of information provided in this document and you assume all risk.

**X839  
Asbestos  
Series**

**Model: C83985-01, 03, 30, 55  
C83905-01, 03, 30, 55  
C83930-01, 03, 30, 55  
15, 30 & 55 Gallon  
Stainless Steel & Painted**

**OPERATION**

**SERVICE**

**PARTS**

**CARE**

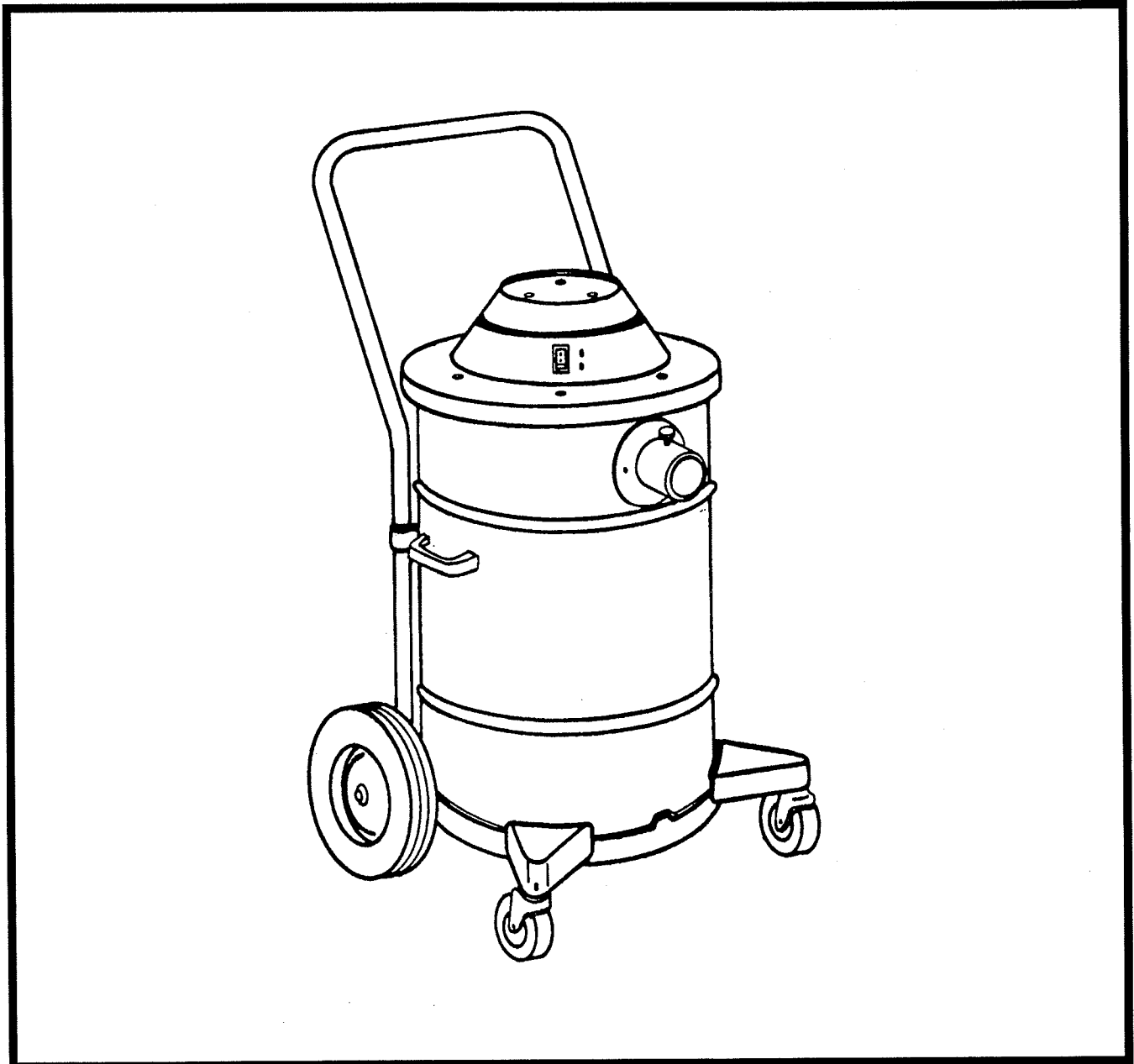

Revised 7/02

**Minuteman<sup>®</sup>**

# **FOR COMMERCIAL USE ONLY**

## **IMPORTANT SAFETY INSTRUCTIONS**

When using an electrical appliance, basic precautions should always be followed, including the following:

### **READ ALL INSTRUCTIONS BEFORE USING**

#### **WARNING - To reduce the risk of fire, electric shock, or injury:**

- Do not leave appliance when plugged in. Unplug from outlet when not in use and before servicing.

#### **WARNING**

Electrical shock could occur if used on wet surfaces. Do not expose to rain. Store indoors.

- Do not allow to be used as a toy. Close attention is necessary when used by or near children.
- Use only as described in this manual. Use only manufacturer's recommended attachments.
- Do not use with damaged cord or plug. If appliance is not working as it should, has been dropped, damaged, left outdoors, or dropped into water, return it to a service center.
- Do not pull or carry by cord, use cord as a handle, close a door on cord, or pull cord around sharp edges or corners. Do not run appliance over cord. Keep cord away from heated surfaces.
- Do not unplug by pulling on cord. To unplug, grasp the plug, not the cord.
- Do not handle plug or appliance with wet hands.
- Do not put any object into openings. Do not use with any opening blocked; keep free of dust, lint, hair, and anything that may reduce air flow.
- Keep hair, loose clothing, fingers, and all parts of body away from openings and moving parts.
- Do not pick up anything that is burning or smoking, such as cigarettes, matches or hot ashes.
- Do not use without dustbag and/or filters in place.
- Turn off all controls before unplugging.
- Use extra care when cleaning on stairs.
- Do not use to pick up flammable or combustible liquids such as gasoline or use in areas where they may be present.
- Connect to a properly grounded outlet only. See grounding instructions.

**SAVE THESE INSTRUCTIONS**

## INSPECTION

Carefully unpack and inspect your machine for shipping damage. Each unit is tested and thoroughly inspected before shipment, and any damage is the responsibility of the delivery carrier who should be notified immediately.

## ELECTRICAL

This machine is designed to operate on a standard 15 amp, 115 volt, 60 hz, AC circuit. Voltages below 105 volts AC or above 125 volts AC could cause serious damage to the motor.

## WARNING

Electric motors can cause explosions when operated near explosive materials or vapors. Do not operate this machine near flammable materials such as solvents, thinners, fuels, grain dust, etc.

## GROUNDING INSTRUCTIONS

This appliance must be grounded. If it should malfunction or breakdown, grounding provides a path of least resistance for electric current to reduce the risk of electric shock. This appliance is equipped with a cord having an equipment-grounding conductor and grounding plug. The plug must be plugged into an appropriate outlet that is properly installed and grounded in accordance with all local codes and ordinances.

**DANGER** - Improper connection of the equipment-grounding conductor can result in a risk of electric shock. Check with a qualified electrician or service person if you are in doubt as to whether the outlet is properly grounded. Do not modify the plug provided with the appliance -- if it will not fit the outlet, have a proper outlet installed by a qualified electrician.

This appliance is for use on a nominal 120-volt circuit and has a grounding plug that looks like the plug illustrated in sketch A below. Make sure that the appliance is connected to an outlet having the same configuration as the plug. No adapter should be used with this appliance.

Sketch A

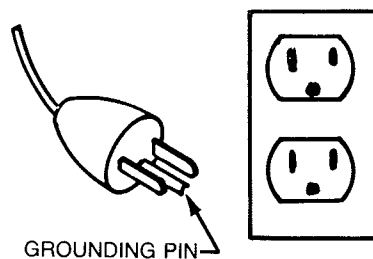

## **USER MAINTENANCE INSTRUCTIONS**

All service and repair should be performed by a qualified vacuum service representative or electrician. No user serviceable components are employed in the electrical vacuum lid head assembly. No lubrication of the motor is required.

### **CLOTH BAG & HOSE ASSY**

Cloth bag and hose assy. are user maintenance items and can be replaced when worn out. Cloth bags can be maintained by blowing dust off of the bag and then laundered. Cloth bags should be completely dried before re-installing into machine. For optimum performance, empty and clean filter bag regularly. A clogged and dirty bag restricts the flow of air and results in reduced vacuum. The Hose Assy. can be maintained by wiping off with a dampened cloth of mild liquid soap and water, then allowed to dry.

### **CORD STORAGE**

While not in use storage can be accomplished by winding cord around motor lid assy. Cord should be completely unwound from Lid Assy. during operation.

- Do not use with damaged cord or plug. If appliance is not working as it should, has been dropped, damaged, left outdoors, or dropped into water, return to service center.
- Do not pull or carry by cord, use cord as handle, close a door on cord, or pull cord around sharp edges or corners. Do not run appliance over cord. Keep cord away from heated surfaces.
- Do not unplug by pulling cord. To unplug, grasp the plug, not the cord.
- Do not handle plug or appliance with wet hands.
- Always unplug the machine when removing the head off the tank. This equipment should be stored indoors and not exposed to rain.

## **OPERATION AND FILTER CARE INSTRUCTIONS**

The Minuteman Asbestos Vacuum has been specifically designed to clean up fibrous asbestos and asbestos dust of all types. Special filters reduce the incidence of airborne dust that would be created by any other method of cleaning.

During the removal of asbestos dust, do not sweep, scoop, shovel, or in any manner handle other than by vacuuming.

Do not at any time attempt to bypass, remove, substitute or by any other means change the filters used in this vacuum.

Use only approved Minuteman Asbestos Vacuum filters and filter bags.

Before attempting to use and before cleaning, be certain that you fully understand the instructions given for the setting up or cleaning/changing of filters of this vacuum.

Each facility has its own individual and unique cleaning problems, it is suggested that you use the following:

### **TANK/FILTER SET-UP PROCEDURE**

Refer to Page 6, figure 1.

1. Fully open the plastic bag and place it down into the tank; #4 on the underside of the intake tube as shown.
2. Take the paper bag that has the cardboard collar attached and open it up by gently pulling the folds apart.
3. You will notice two creases on the top side of the collar; carefully bend the ends down (toward) the bag.
4. Insert this bag into the tank and push it to the bottom, taking care not to snag the plastic bag.
5. Locate the cardboard collar around the intake tube and gently work it up past the raised ring that runs around the tube.
6. Push the plastic bag down past the paper bag; position it about 1/2 to 2/3 down past the top of the bag.
7. Take the paper filter protector bag and insert it into the tank and snap the elastic band around the rim of the tank. (About 2 inches of the bag should be outside of the tank.)
8. Place the cloth filter bag onto and into the tank, using the formed outer rim as a guide and press down firmly onto the tank rim.
9. Position the lid onto the tank, making sure that the gasket of the lid is seated onto the ring of the cloth bag frame completely around the tank.
10. Snap the lid latches into place.

For proper cleaning of tank and removal/changing of filters, see "Procedure for Removing Contaminated Filters and for Cleaning of Contaminated Tank".

### **PROCEDURE FOR REMOVING CONTAMINATED FILTERS AND FOR CLEANING OF CONTAMINATED TANK**

For the benefit of your health, you should always wear a face mask approved for use with asbestos any time you are using or cleaning this vacuum cleaner. You should also wear gloves.

1. Unplug machine from power source.
2. Carefully and slowly remove lid only (be sure you have not accidentally lifted the cloth filter bag at the same time). Set the lid/filter assembly aside.
3. Gently tap the inside of the cloth bag to loosen any particles that may be on the opposite surface. Do this all around the inside surface of the bag.
4. Gently remove the cloth bag and set aside.
5. Carefully undo the elastic band from around the tank and push the entire bag "slowly" into the tank. Do not allow the elastic band to snap the bag closed.
6. Using a wiping cloth, dampened with water (not soaking wet), wipe down all of the exposed surfaces inside to the tank; put the cloth aside, do not discard.
7. Carefully and "very" slowly, push the paper bag down and off of the intake tube, using the attached cardboard collar. After the collar is removed from the intake tube, take the damp cloth and wipe off any surfaces that were not previously wiped; at this time, re-wipe the entire inside of the tank and drop the wiping cloth into the tank.
8. Now reach in and gently pull up and around the paper bag the plastic bag that had been previously inserted. When you have the plastic bag fully extended, "gently" and "slowly" squeeze the bag closed as close to the filled bag as possible in order to avoid trapping excessive air.
9. Gently remove the bag from the tank. Twist the unfilled portion closed and tie it into a knot.
10. CAUTION: Hazardous materials must be disposed of properly. Never throw contaminated debris in your usual trash receptacle. Place debris in a plastic bag or can marked "HAZARDOUS MATERIALS" and take to a hazardous waste handler.
11. For proper assembly of new filters, see "Tank/Filter Set-Up Procedure".

## CHANGING THE PINK IMPACTION PREFILTER

Refer to Item No. 37, Page 7.

The pink impaction filter should be changed, using all of the precautions previously mentioned. The impaction filter should be changed when any of the following takes place:

1. Anytime there is an indication of a filter tear during normal operation of the unit. This tear could be in any of the filters used.
  - a. paper dust containment bag
  - b. paper bag protector
  - c. cloth filter bagThese tears would show up during the tank clean-out procedure, or....
2. Every other tank clean-out period. To change the impaction filter, do the following before you do Step #3 of the normal clean-out procedure.
  - a. Wipe down all of the exposed surfaces on the underside of the removed lid, using the dampened wiping cloth.
  - b. Carefully unclamp filter retainer from the side of the filter. Set the retainer aside.
  - c. Remove the impact filter from the high efficiency filter. Be careful so as not to damage or puncture the H.E.P.A. media used in the final filter. Do not attempt to clean the pink impact filter in any way; dispose of by placing it into the tank you are now in the process of cleaning. **DO NOT USE ANY TOOLS TO REMOVE THE IMPACT FILTER.**
  - d. Before proceeding any further in cleaning the tank, first place a new impact filter (one only) onto the H.E.P.A. filter. Replace the impact retainer and lock it into place by reclamping.

## ASSEMBLY PROCEDURE FOR DRY RECOVERY

Models 30/55 gallon

(See schematic on Page 6, figure 2)

1. Place 6 mil. plastic bag liner #7 into drum. Drape bag liner over rim of drum.
2. Place adaptor ring #6 onto drum.
3. Insert paper filter protector #3 into drum adaptor ring and drape elastic over rim to secure in place.
4. Insert cloth filter assembly #2 into adaptor ring and center around rim.
5. Place vacuum motor lid assembly onto adaptor ring. Attach lid latches.

## EMPTYING PROCEDURE AFTER DRY RECOVERY

1. Remove the vacuum lid assembly and place on work table upside down.
2. Remove and inspect cloth filter assembly. If dust has accumulated on the cloth bag, it will require cleaning by vacuuming. A second cloth filter assembly should be kept on hand for installation into vacuum so that soiled filter bag can be cleaned and reused.
3. Remove filter bag protector elastic from around adaptor rim and push bag into drum for disposal.
4. Inspect pink impact prefilter on underside of H.E.P.A. filter on vacuum motor lid assembly. If pink filter has been soiled, remove by unclamping ring retainer #38, page 7, remove screen and remove pink filter #37, and place it into drum with other debris.
5. Install clean pink impact prefilter onto H.E.P.A. filter. Replace screen and clamp on retainer ring.
6. Using a damp towel, wipe inside of adaptor ring as you remove it from drum. Place soiled towels into drum liner bag.
7. Gather plastic liner bag while in drum. Seal and tie liner bag before removing from drum. Tilt drum over on its side and slide bag liner out of drum. Place into a second 6 mil. liner bag with proper markings for disposal.
8. Follow assembly procedure above before putting vacuum back into use.

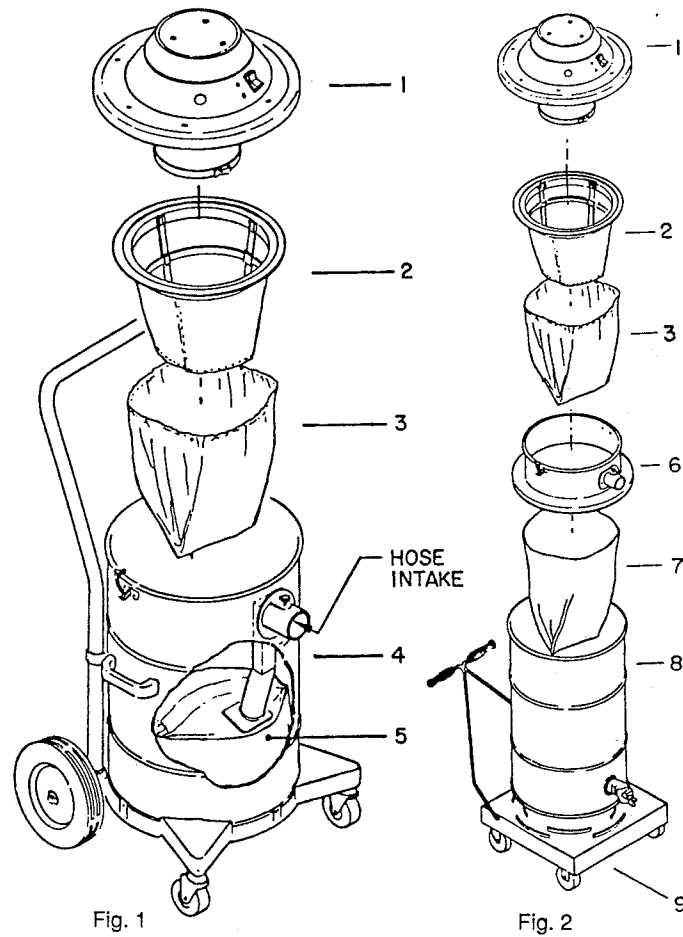

ITEM NO.	PART NO.	DESCRIPTION
1	801085 (85)	Lid asy. comp.
	801105 (105)	Lid asy. comp.
	801130 (130)	Lid asy. comp.
2	805057	Cloth bag asy. comp.
3	805038 Pkg	Disposable filter protector pkg of 12
4	750220	Tank asy. comp. 15 gallon stainless steel
	750221	Tank asy. comp. 15 gallon painted
5	760598 Pkg	Disposable paper bag
	805037 Pkg	Disposable plastic bag
6	C80601-70	Adapter comp. 30 gallon
	C80601-80	Adapter comp. 55 gallon
7	805037 Pkg	Drum liner 30 gallon
	805046 Pkg	Drum liner 55 gallon
8	C90007-80	30 gallon drum
	900015 Ptd	55 gallon drum
9	900048	Dolly cart comp 30/55 gallon

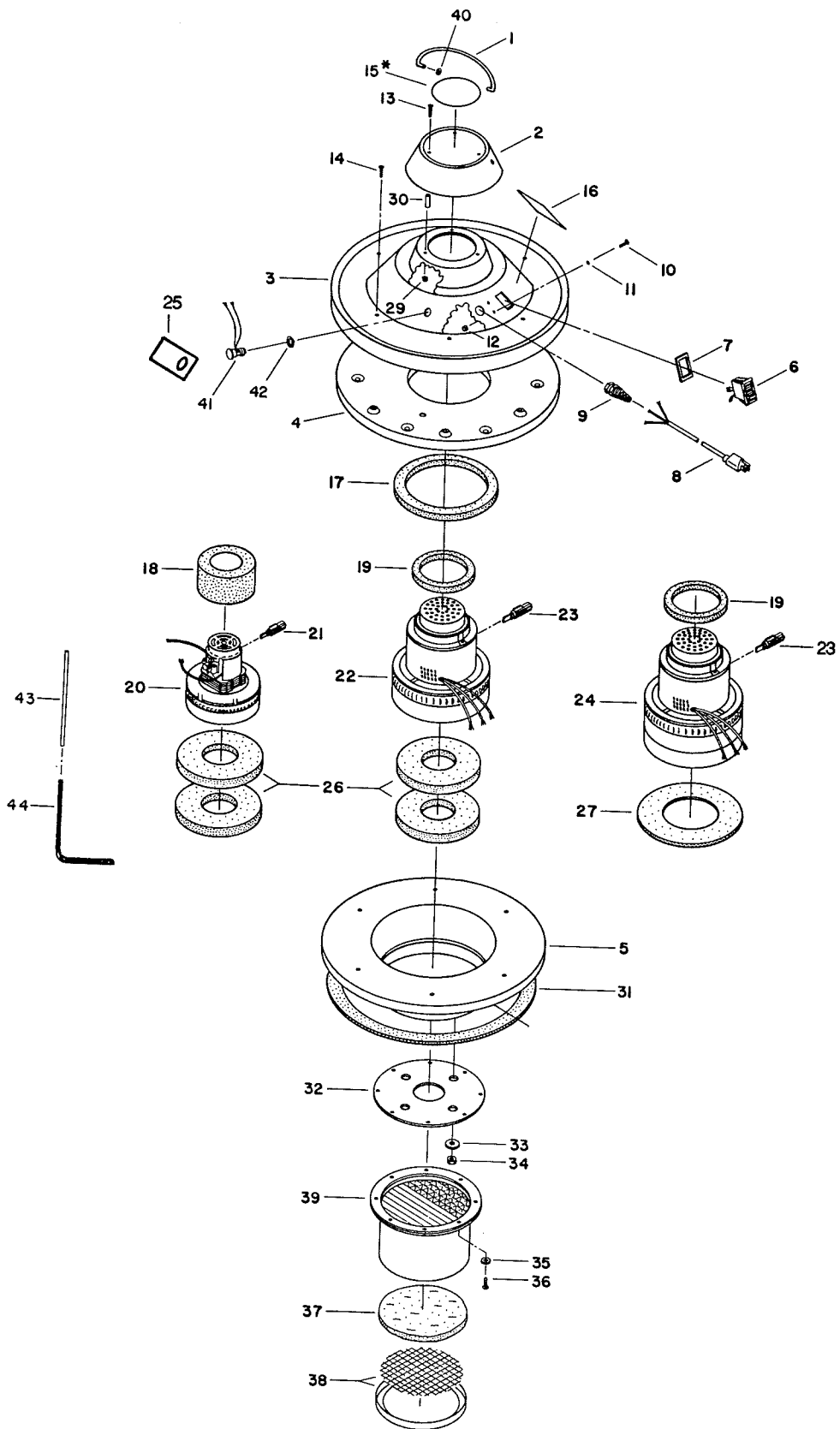

## Vac Head Assembly

ITEM NO.	PART NO.	QTY.	DESCRIPTION
1	760899	1	Handle bail
2	760898PLT	1	Cap, motor
3	760897PLT	1	Cover, motor
4	760902	1	Motor hold down P/V HEPA
5	760903	1	Motor lid asy. P/V HEPA
6	809754	1	Switch, rocker
7	831543	1	Gasket, diecut switch
8	381020	1	Orange cord set 16-3, 50'
9	833237	1	Strain relief
10	710355	2	SCR-MC 10-32 x .50 ST PL
11	711553	3	WSR-Internal Lock #10
12	711310	2	Nut-Hex 10-32 ST PL
13	712823	3	SCR-Thms 10-24 x 1.00 ST PL
14	711129	6	SCR-ST-B 10 x 1.00 PL
15	715102	1	Decal, P/V HEPA 85
	715103	1	Decal, P/V HEPA 105
	715104	1	Decal, P/V HEPA 130
16	715115	1	Decal, diecut warning
17	831478	1	Gasket, neop. 6 x 7.5 x .37
18	380064	1	Ring, foam
19	831484	1	Gasket, 3.5 x 4.5 x .31
20	380001	1	Vacuum motor, bypass 115V-85
21	380028	2	Brush, carbon-85
22	255039	1	Vacuum motor, bypass 115V-105
23	255008	2	Brush, carbon-105/130
24	831524	1	Vacuum motor, 3 stage 115V-130
25	715069	1	Decal diecut check filter
26	828995	2	Gasket, neop. 2.5 x 6 x .62
27	831626	1	Gasket 4 x 7.37 x .250
29	712908	3	Nut-flanged wizz 10-24
30	831652	3	Spacer
31	760900	1	Lid, gasket .12 x .75 50" PS
32	110012	1	Plate, mounting (110010)
	110003	1	Plate, mounting (110001)
33	711519	4	WSR-Flat .25 x 1.01 x .06
34	711373	4	Nut-Nyloc 1/4-20
35	711552	8	WSR-Internal lock #8
36	710328	8	SCR-MC 8-32 x .37 ST PL
37	110121PKG	1	Impact filter sm. rd. pkg.
	703007PKG	1	Impact filter lg. rd. pkg.
38	750006	1	Retainer impact asy. comp. (110010)
	750011	1	Impact retainer asy. comp. (110001)
39	110010	1	HEPA filter copolm (801085)
	110001	1	HEPA filter copolm (801105, 801130)
40	805073	2	Pin, cotter
41	740088	1	Vac light sensor switch
42	711715	1	Retaining ring-ext. .75
43	760213	1	Venturi tube
44	760212	1	Vac sensor tube
***	801085		Lid asy. comp. (85)
***	801105		Lid asy. comp. (105)
***	801130		Lid asy. comp. (130)

15 GALLON PAINTED/STAINLESS STEEL TANK WITH MOLDED INTAKE

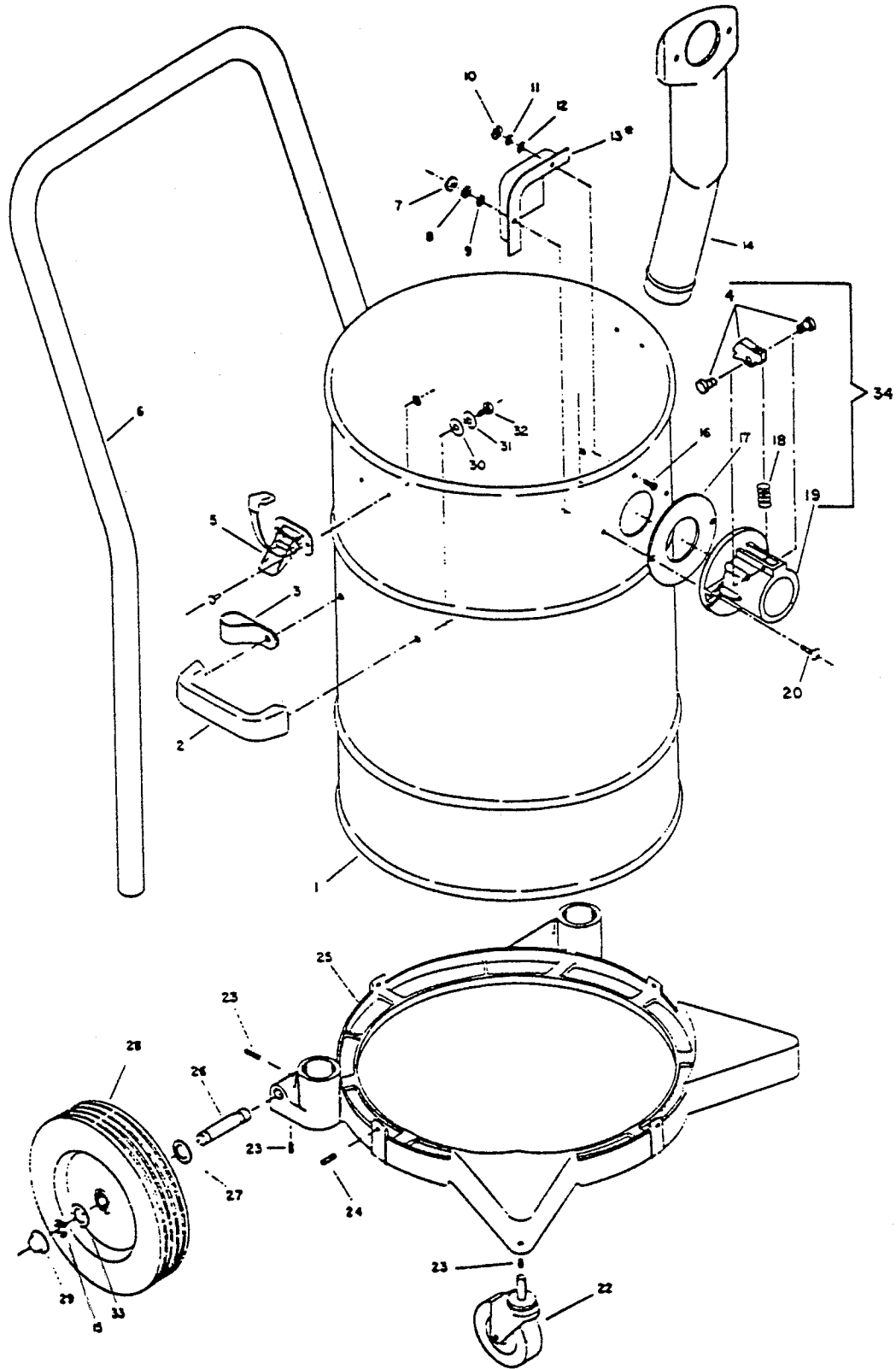

## Parts List

Item	Part No.	Qty.	Description
1	900001	1	Tank, PTD 15 Gal
1A	900003POL	1	Tank, Polished 15 Gal SS
2	900031	1	Handle, Tank Polished
3	900038	2	Clamp, Handle
4	390001	1	Trigger with Pins
5	761054	2	Latch
6	900037PLT	1	Handle, Plated
7	711310	2	Nut-Hex 10-32 ST PL
8	711543	2	Washer-Helical #10
9	711503	2	Washer-Flat #10
10	711304	1	Nut-Hex 8-32 ST PL
11	711542	1	Washer-Helical #8
12	711502	1	Washer-Flat #8
13	900035	1	Deflector, Intake
14	390016	1	Molded Downtube, New Style
15	711713	2	Retaining Ring-E Ext
16	710530	1	SCR-MC 8-32 x .5 BR
17	390087	1	Gasket
18	390002	1	Spring
19	390101	1	Intake Aluminum
20	710154	2	SCR-MC 10-32 x .562 SS
21			
22	900033	2	Caster, Swivel
23	711005	4	SCR-SK 1/4-20 x .31
24	711006	6	SCR-SK 1/4-20 x .62
25	760984PTD	1	Bracket, Wheel
26	900066	2	Axle
27	711524	2	Washer-Wave .52 x .87 x .01
28	900040	2	Wheel
29	130032	2	Cap, Retainer
30	711591	4	Washer-Rubber
31	711505	4	Washer-Flat
32	711203	4	Bolt-HH 1/4-20 x .62
33	711594	2	Washer-Flat .88 x .03 NI
34	390110	1	Intake Assy Aluminum
***	390013		Molded Adapter 1-1/4
***	390014		Molded Adapter 1-1/2
***	390019		Molded Adapter 2
***	750220		Tank Assy Comp 15 Gal PTD Asbestos
***	750221		Tank Assy Comp 15 Gal SS Asbestos
***	750322		Wheel Bracket Assy Comp
***	750381		Tank Assy Comp PTD w/Deflector
***	750382		Tank Assy Comp SS w/Deflector

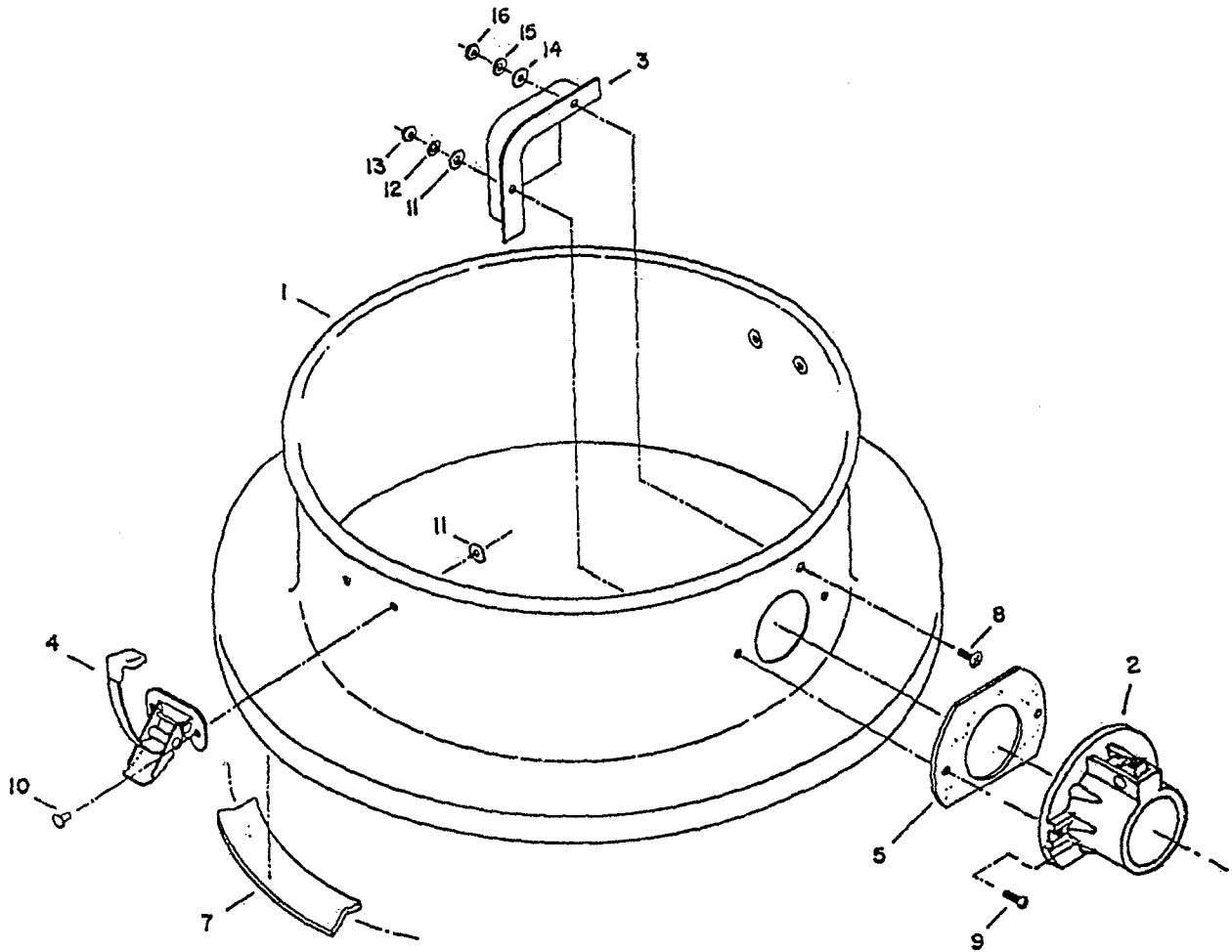

### PARTS LIST

Item	Part No.	Qty	Description
1	806016PTD	1	55 Gal. Adapter Painted
1a	806015PTD	1	30 Gal. Adapter Painted
2	390110	1	Intake Assy Aluminum
3	900035	1	Deflector, Intake
4	761054	2	Latch
5	390087	1	Gasket Diecut Poron Intake
7	806006	1	Gasket, Raw
8	710530	1	SCR-MC 8-32 x .50 BR
9	712824	2	SCR-THMS 10-24 x .75 STPL
10	711915	4	Rivet-Tube .19 x .28 NI PL
11	711503	6	WSR-Flat #10
12	711543	2	WSR-Helical #10
13	712638	2	Nut Hex 10/24 SS Nyloc
14	711502	1	WSR-Flat #8
15	711542	1	WSR-Helical #8
16	711304	1	Nut-Hex 8-32 STPL
****	C80601-70		30 Gal. Adapter Assy.
****	C80601-80		55 Gal. Adapter Assy.

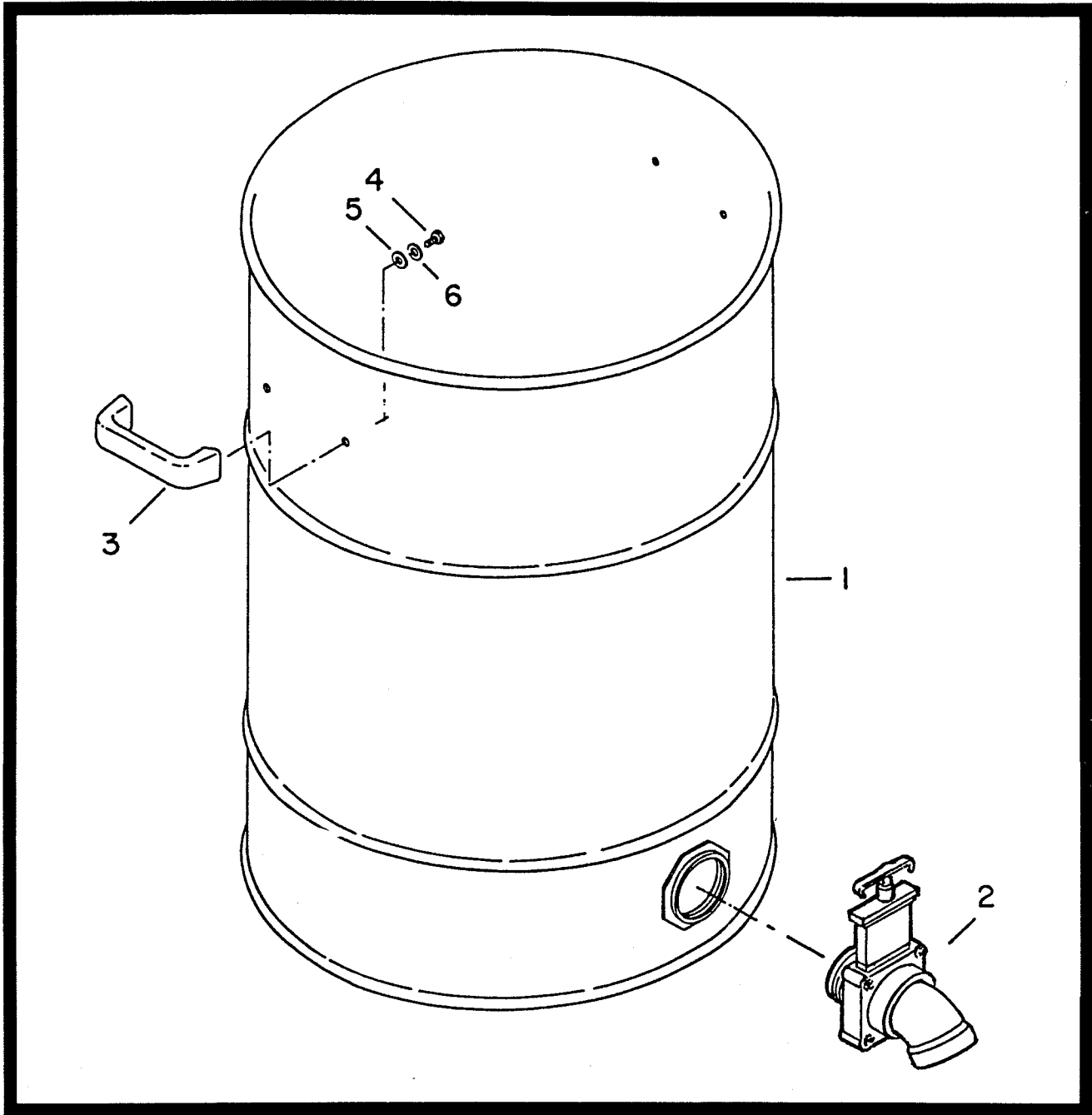

### PARTS LIST

Item	Part No.	Qty	Description
1	900078PTD	1	Tank 30 Gal. PTD Less Handles
1a	900015PTD	1	Tank 55 Gal. PTD No Handles
2	900047	1	Dump Valve
3	900031POL	2	Handle, Tank Polished
4	711203	4	BLT, HH 1/4-20 x .62
5	711591	4	Washer, Rubber
6	711505	4	WSR, Flat 1/4
***	C90007-80		Tank 30 Gal. Complete
***	805037PKG		Drum Liner 30 Gal. Pkg. 12
***	805046PKG		Drum Liner 55 Gal. Pkg. 12

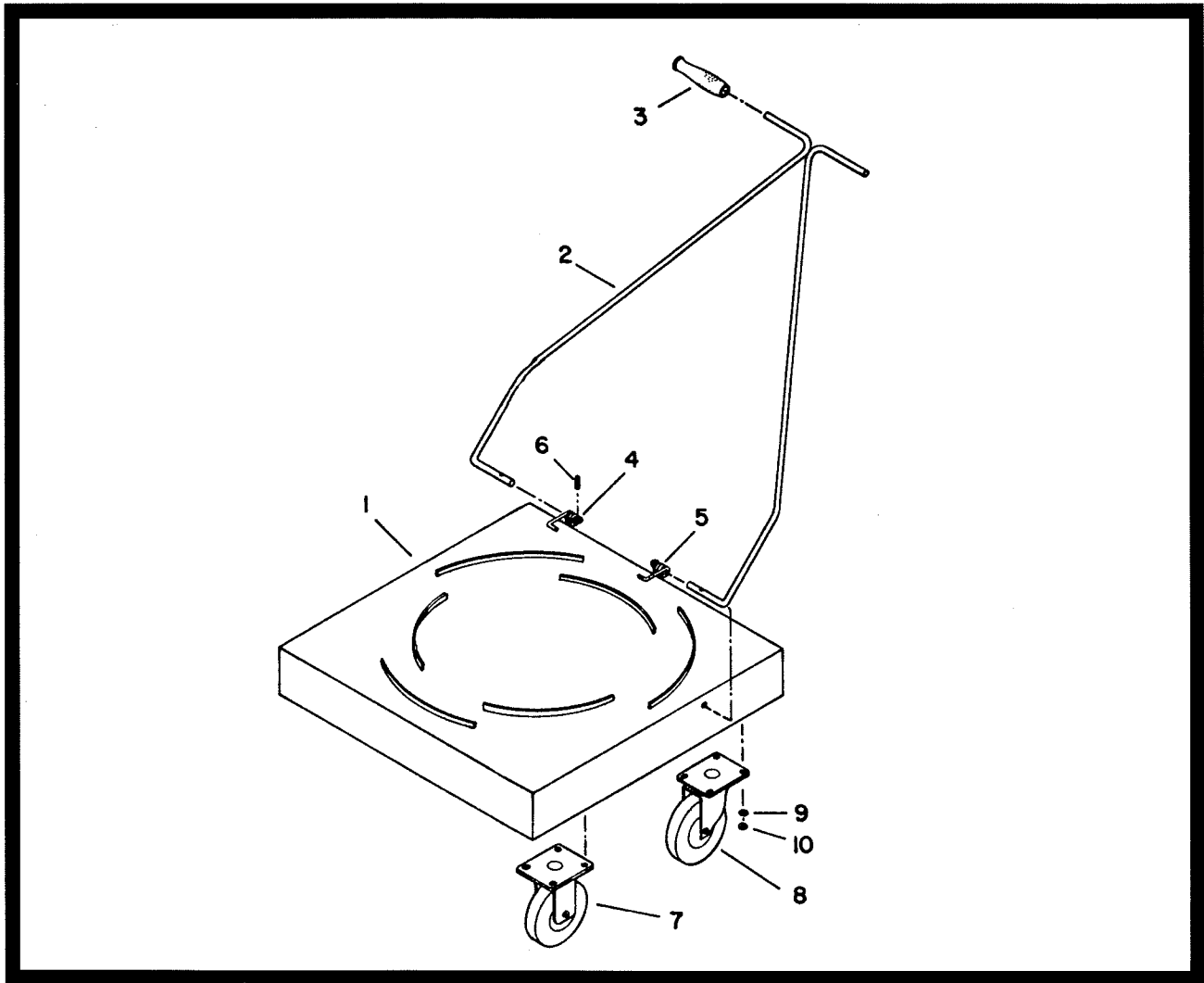

### Parts Listings

Item	Part No.	Qty	Description
1	750045	1	Weldment dolly 30/55
2	900051	1	Weldment, handle
3	900052	2	Grip, handle
4	900080	1	Spring, torsion RH
5	900081	1	Spring LH
6	711642	2	Rollpin
7	761050	2	Caster, rigid 5"
8	761049	2	Caster, swivel 5"
9	711545	16	WSR, helical Spr Loc 5/16
10	711319	16	Nut-Hex 5/16-18 ST PL
***	900048		Dolly cart complete

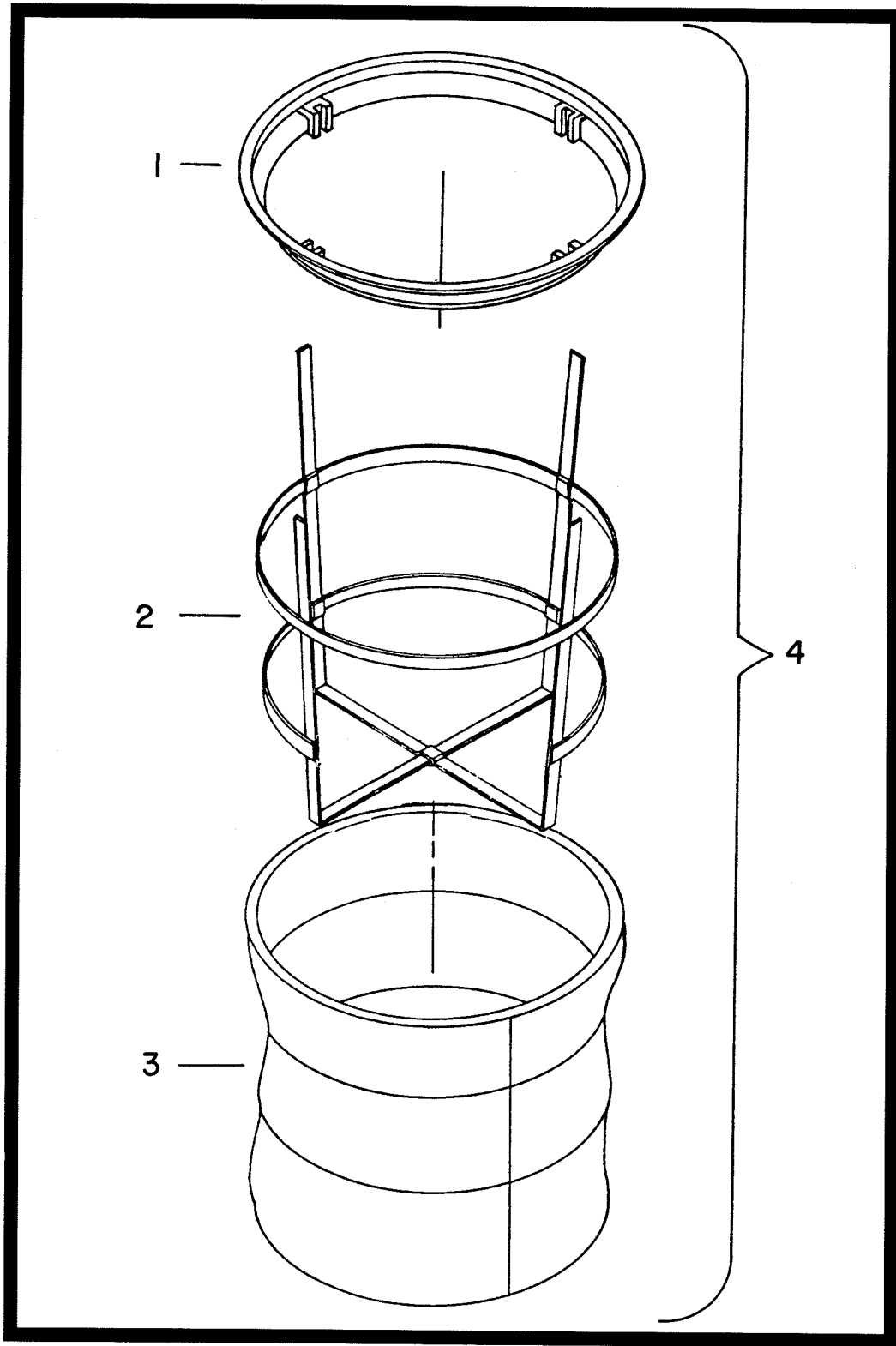

ITEM NO.	PART NO.	QTY	DESCRIPTION
1	760131	1	Molded bag ring
2	750097	1	Bag frame
3	805054	1	Cloth bag only
4	805057	1	Bag asy. complete

# LIMITED WARRANTY

Minuteman International, Inc. warrants to the original purchaser/user that this product is free from defects in workmanship and materials under normal use and service for a period of three years from date of purchase. In addition, Minuteman International, Inc. will, at its option, honor labor warranty claims for the first 12 months from date of sale, provided such claims are submitted through and approved by factory authorized repair stations. Minuteman International, Inc. will, at its option, repair or replace without charge, except for transportation costs, parts that fail under normal use and service when operated and maintained in accordance with the applicable operation and instruction manuals.

This warranty does not apply to normal wear, or to items whose life is dependent on their use and care, such as belts, cords, switches, hoses, rubber parts, electrical motor components or adjustments. Parts not manufactured by Minuteman International, Inc. such as engines, batteries, battery chargers, hydraulic pumps, and tires are covered by and subject to the warranties and/or guarantees of their manufacturers. Please contact Minuteman International, Inc. for procedures in warranty claims against these manufacturers.

**Special warning to purchaser** — Use of replacement filters and/or prefilters not manufactured by Minuteman International, Inc. or its designated licensees, will void all warranties expressed or implied.

A potential health hazard exists without exact original equipment replacement.

All warranted items become the sole property of Minuteman International, Inc. or its original manufacturer, whichever the case may be.

Minuteman International, Inc. disclaims any implied warranty, including the warranty of merchantability and the warranty of fitness for a particular purpose. Minuteman International, Inc. assumes no responsibility for any special, incidental or consequential damages.

This limited warranty is applicable only in the U.S.A. and Canada, and is extended only to the original user/purchaser of this product. Customers outside the U.S.A. and Canada should contact their local distributor for export warranty policies. Minuteman International, Inc. is not responsible for costs or repairs performed by persons other than those specifically authorized by Minuteman International, Inc. This warranty does not apply to damage from transportation, alterations by unauthorized persons, misuse or abuse of the equipment, use of non-compatible chemicals, or damage to property, or loss of income due to malfunctions of the product.

If a difficulty develops with this machine, you should contact the dealer from whom it was purchased.

This warranty gives you specific legal rights, and you may have other rights which vary from state to state. Some states do not allow the exclusion or limitation of special, incidental or consequential damages, or limitations on how long an implied warranty lasts, so the above exclusions and limitations may not apply to you.

## **Minuteman**<sup>®</sup>

**World Headquarters**  
Minuteman International, Inc.  
111 South Rohlwing Road  
Addison, Illinois 60101

Minuteman Canada, Inc.  
2210 Drew Road  
Mississauga, Ontario  
L5S 1B1

(630) 627-6900  
FAX (630) 627-1130

(905) 673-3222  
FAX (905) 673-5161

987846  
Printed in U.S.A.