



## Electronic Service Manuals

This electronic document is provided as a service to our customers. We do not create the contents of the information contained in this document. Should you have detailed questions pertaining to the information contained in this document, you may contact Michco, or the manufacturer which provided the original information in this electronic deliverable. Michco's only part in this electronic deliverable was the electronic assembly process.

You may contact Michco through the following methods:  
Phone (517) 484-9312 or (800) 331-3339 MI, OH, IN only  
2011 N. High St. -- Lansing, Michigan -- 48906  
Fax: (517) 484-9836  
Email: [CustServ@Michco.com](mailto:CustServ@Michco.com)  
Web site: [www.Michco.Com](http://www.Michco.Com)  
Parts Web site: [www.FloorMachineParts.Com](http://www.FloorMachineParts.Com)

Order Parts on Line at:  
**[www.FloorMachineParts.Com](http://www.FloorMachineParts.Com)**

Directly to Parts & Service:  
By Email: **[Shop@Michco.com](mailto:Shop@Michco.com)**  
By Fax: (517) 702-2041  
By Voice: Use numbers above.

**Serving the Cleaning Industry Since 1922**

Notice: All copyrighted material remains property of original owners, all trademarks are property of respective owners. Manuals are subject to Manufacturer's reproduction limitations. Originals or reproductions were provided by manufacturers through a request. We make no warranty as to the correctness of information provided in this document and you assume all risk.

## DIFFERENTIAL CONVERSION KIT FOR VAC-35 AND HURRICANE

**Part No.**  
**MA-588-C**

### SERVICE BULLETIN

Read all instructions completely before attempting to do any work. Do not discard or misplace any of the parts being removed from the unit, as some of them will be reused.

### ASSEMBLY INSTRUCTIONS FOR VAC-35

#### TO REMOVE OLD DIFFERENTIAL

1. Set the unit up on blocks. Make sure unit is stable enough to work on. Serious injury and/or damage to unit could occur if unit is allowed to fall from blocks.
2. Remove the cotter pins and clevis pins or bolts (where applicable) that secure the wheels to the axle shafts of the differential, and remove wheels.
3. Also remove all bushings, washers or wheel spacers from the axle shafts (where applicable).
4. Remove the chain guard and the shaft guard from the unit.
5. If the unit is equipped with the wooden chain tensioner, loosen nut holding chain tensioner to chassis and slide tensioner to back of chassis away from chain. For units equipped with the bearing assemblies that have slotted holes, loosen nuts holding bearings to chassis and slide back to release tension from chain.
6. Remove the master link from the chain running from the jackshaft to the differential and remove chain from unit.
7. Remove the bearings from the chassis and from the differential.
8. Remove the differential from unit.

NOTE: Although it is not necessary, it may be desirable to remove the left hand handle back brace to allow more working space.

#### CHASSIS MODIFICATIONS

NOTE: Some modification must be made to chassis before new differential can be assembled. Follow these instructions

1. A small section from chassis must be cut away before new differential can be assembled. Using a scale or tape measure, measure from the back left hand side of unit, up the left hand side next to existing slot for differential, and make a mark at seven (7) and nine (9) inches (See A1 - 576 below).
2. With a carpenter square or another instrument with a ninety degree plane, extend a line from edge of chassis to existing slot for differential, at the marks made in Step 1.
3. Using a hand held hacksaw or saber saw cut along lines established in Step 2, from inside existing hole for differential toward left hand side of unit.

IMPORTANT! Do not cut any further than the bottom of the corner radius. (See AF-576)

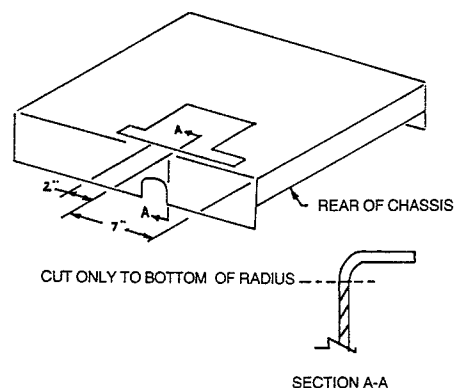

4. Grip the piece just cut, between the cuts with vice-grips

# SERVICE BULLETIN

## ASSEMBLY INSTRUCTIONS (Con't)

### TO ASSEMBLE NEW DIFFERENTIAL

1. Place new differential on chassis in its proper location.
2. Slide new bearing assemblies, supplied with kit, onto axles of differential.
3. Using the hardware removed from the original bearings, assemble the new bearings to chassis. Do not tighten.

NOTE: Four (4) 3/8 flatwashers have been supplied with this kit. If the unit did not originally have flatwashers on the bolts securing the bearings, it will be necessary to assemble these on the bolts before assembling bearings to chassis.

4. Before replacing chain to differential and jackshaft, one link must be removed and an offset or half link, supplied with kit, must be assembled in its place. Once this is complete, assemble chain to differential and jackshaft. If chain has a twist or bow in it, check the alignment of the sprocket on differential with that of the jackshaft. Alignment should be within .030 inch.
5. Slide the bearings back (toward rear of chassis) as far as the slotted holes will permit. Tighten hardware.

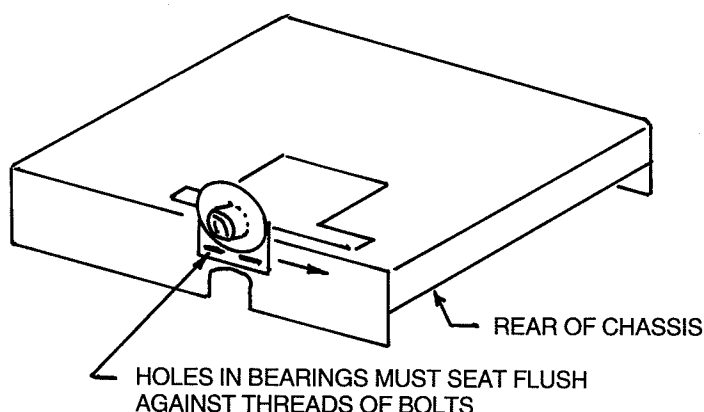

NOTE: No part of the differential should be touching the shroud or starter rewind of engine, if assembled properly. If an interference is present, check to make sure bearings are assembled properly. If an interference is present, check to make sure bearings are assembled properly. The slotted holes in bearings should be seated against the threads of the bolts. Make sure that the flatwashers don't have any sharp edges or burrs that are catching in the slotted holes of bearings.

6. To re-adjust chain tensioner, push forward against the chain as far as it will go, then back it off about 1/8 of an inch and tighten hardware.
7. Replace the chain guard and shaft guard.
8. Replace the original bushings, washers or wheel spacers.
9. Place the wheels on the axles of differential. Line up the holes in hub of wheels with those in axles. Check the wheels for any space between wheels and bearings. Four (4) special washers have been supplied with this kit. Use these on axle as needed to eliminate any play that may be present. Remove the wheels and place washer(s) on shaft behind wheels, if two are required place one on each side of wheel spacer, bushing, etc. Replace wheels.
10. Replace the clevis pins and cotter pins or bolts that secure wheels to axles.

NOTE: Replace left hand handle back brace if it was removed in the earlier steps of these instructions.

# DIFFERENTIAL CONVERSION KIT FOR HURRICANE

## ASSEMBLY INSTRUCTIONS FOR HURRICANE

1. Set the unit up on blocks. Make sure unit is stable enough to work on. Serious injury and/or damage to unit could occur if unit is allowed to fall from blocks.
2. Remove the cotter pins and clevis pins or bolts (where applicable) that secure the wheels to the axle shafts of the differential, and remove wheels.
3. Also remove all bushings, washers or wheel spacers from the axle shafts (where applicable).
4. Remove the master link from the chain running from the jackshaft to the differential and remove chain from unit.
5. Remove the bearings from the chassis and from the differential.
6. Remove the differential from unit.

## TO ASSEMBLE NEW DIFFERENTIAL

1. Place new differential on chassis in its proper location.
2. Slide new bearing assemblies, supplied with kit, onto axles of differential.

3. Using the hardware removed from the original bearings, assemble the new bearings to chassis. Do not tighten.
4. Assemble chain to differential and jackshaft. If chain has a twist or bow in it check the alignment of the sprocket on differential with that of the jackshaft. Alignment should be within .030 inch.
5. Replace the original bushings, washers or wheel spaces.
6. Place the wheels on the axles of differential. Line up the holes in hub of wheels with those in axles. Check the wheels for any space between wheels and bearings. Four (4) special washers have been supplied with this kit. Use these on axle as needed to eliminate any play that may be present. Remove the wheels and place washer(s) on shaft behind wheels, if two are required place one on each side of wheel spacer, bushing, etc. Replace wheels.
7. Replace the clevis pins and cotter pins or bolts that secure wheels to axles.
8. Slide the bearings back (toward rear of chassis) as far as the slotted holes will permit. Tighten hardware.

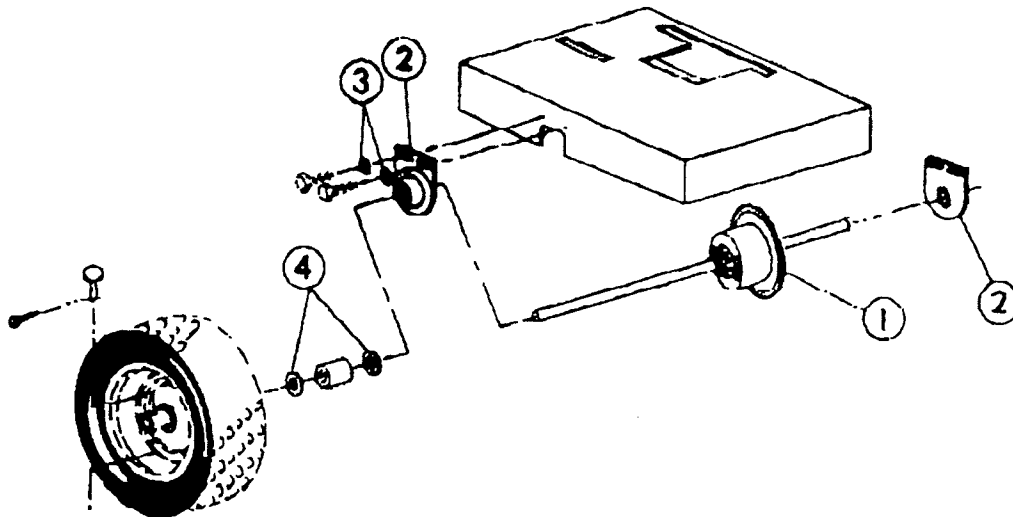

## PARTS LIST

Item	Part No.	Qty.	Description
1	SA-1243-D	1	Differential Assembly
2	SA-817-B	2	Bearing Assembly Mod.
3	81-166-A	4	Special Washer 3/8
4	66-431-A	4	Special Washer

# DIFFERENTIAL CONVERSION KIT FOR VAC-35

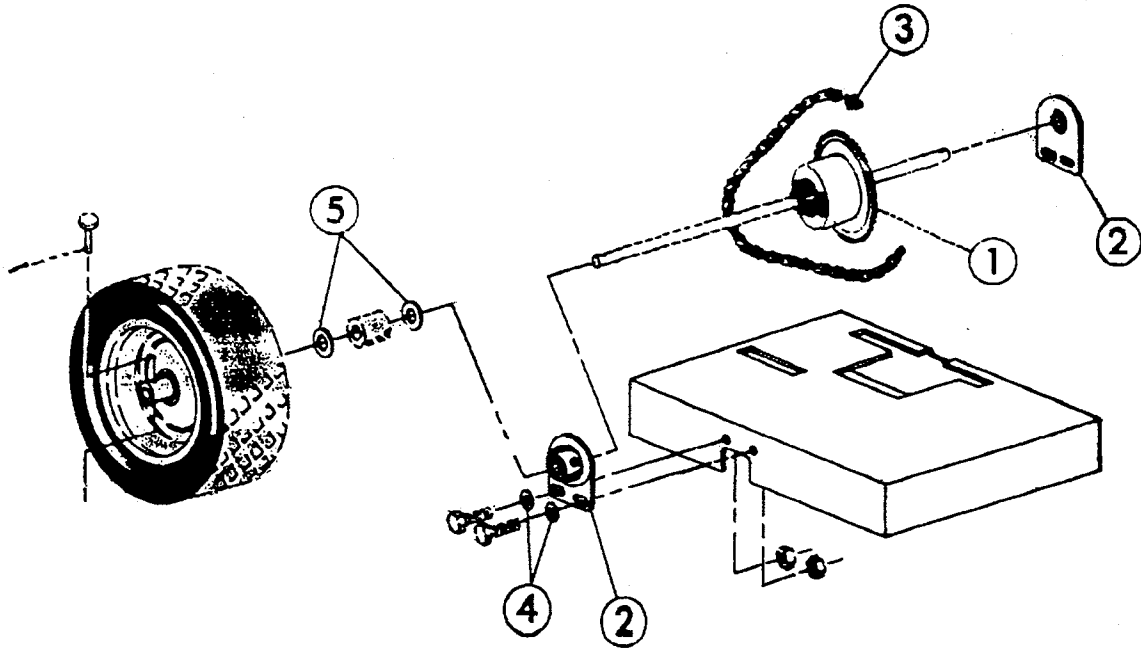

## PARTS LIST

Item	Part No.	Qty.	Description
1	SA-1243-C	1	Differential Assembly
2	SA-817-B	2	Bearing Assembly Mod.
3	84-41-B-5	1	Offset Chain Link
4	81-166-A	4	Special Washer 3/8
5	66-431-A	4	Special Washer

# Parker®

**Parker Sweeper Company**  
*A Division of Minuteman International, Inc.*  
 111 South Rohlwing Road  
 Addison, Illinois 60101  
 Phone: (630) 627-6900  
 Fax: (630) 627-1130