

KENT

AREA CLEANER KIT



MODELS:
KT-12, KT-15,
KT-15P, KT-15-2

INSTRUCTIONS & ILLUSTRATED PARTS LIST

JULY 1992

THE KENT COMPANY
P.O. Box 1665
2310 Industrial Parkway
Elkhart, IN 46515
TEL: (219)293-8661, (800)334-1083
(800)642-6635 (Indiana)
FAX: (219)295-8610
TELEX: 25-8331 KENT CO EKR

ASSEMBLY INSTRUCTIONS

Step 1.

Disconnect power cord and remove Vac Head Assembly and Accessory Basket.

Step 2.

Turn the Tank Assembly upside down.

Step 3.

Make sure that the axle weldment assembly remains in its position when installing the Area Cleaner onto the tank.

Step 4.

After the axle weldment assembly mounting screws are removed, position the Area Cleaner Assembly Complete, aligning the holes before fastening securely using 04254 Washers (Det. 6) and 02254 Screws, 1/4-20 x 7/8 (Det. 9).

Step 5.

Turn the Tank Assembly right side up and reassemble Accessory Basket and Vac Head Assembly. Assemble 39454 Hose Assembly into tank inlet and other end into Area Cleaner tube. Your vacuum is now ready for use.

NOTE: TOOL NEEDED

7/16" open or box end wrench.

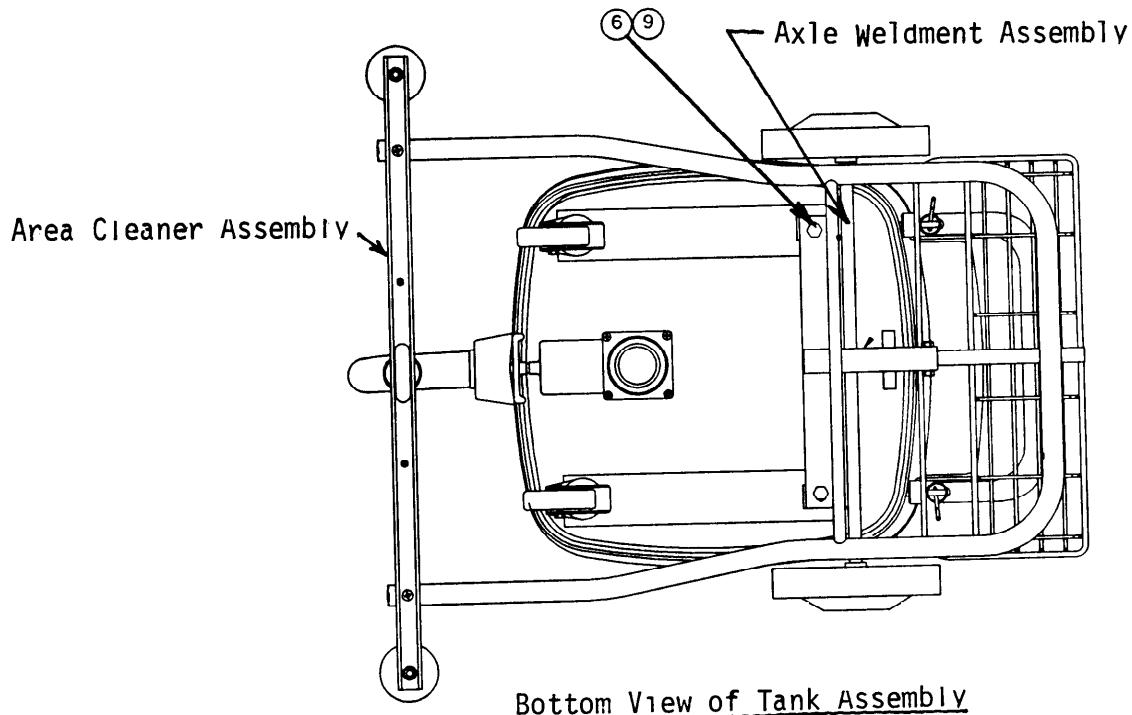

1.	039454	HOSE ASM.	1
2.	053510	KNOB, PLASTIC	2
3.	054889	FERRULE	1
4.	039452	WDMT, SUPPORT--HINGE	1
5.	039456	WDMT, LATCH	1
6.	004254	WSHR, LOCK--1/4 EXT.	2
7.	054880	SQUEEGEE BODY W/BLADES	1
7.	039289	BLADE, SET OF 2	1
8.	055729	END CAP--MYLAR	2
9.	002254	SCR, 1/4-20 X 7/8, HH	2
10.	055732	ARM, AREA CLEANER	1
11.	046156	BUTTON, PLUG	2
12.	E26242-1	WHEEL--2.62 DIA.	2

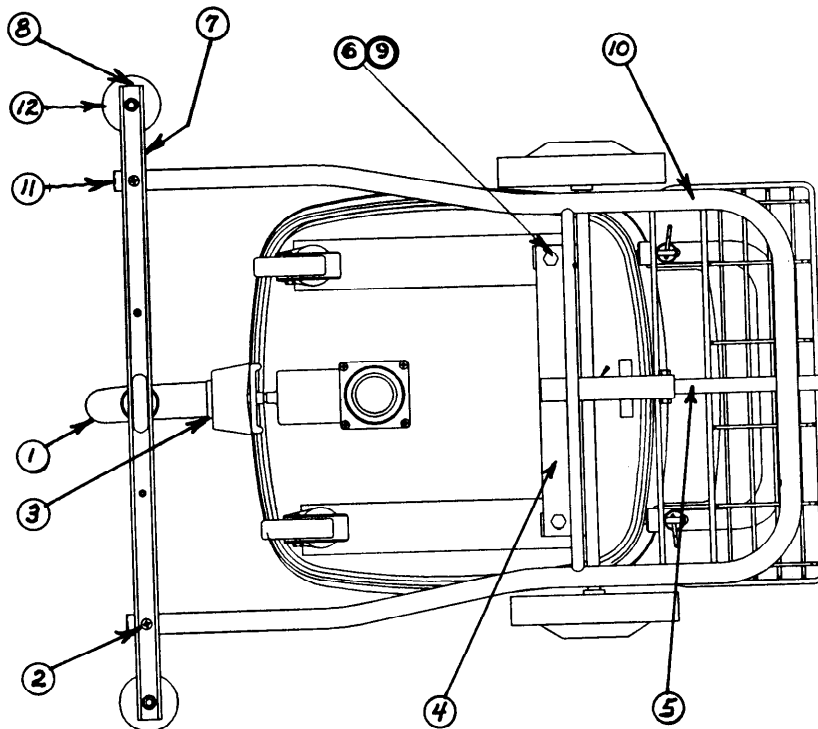

THE KENT LIMITED WARRANTY

Your Kent equipment which has been manufactured, tested and inspected in accordance with carefully specified engineering requirements, is warranted to be free from defects in material and workmanship. This warranty is, however, subject to the following qualifications, conditions, and limitations which are set forth to provide you and all users of the Kent equipment with information concerning the duration, extent, availability, and applicability of this Kent limited warranty, the procedure to be taken to obtain its performance, and other information concerning the Kent warranty policy.

The Kent Limited Warranty is extended to the original end user as follows:

Wet/Dry tank vacuums except environmental vacuums HEPA filter equipped 3 year parts replacement and 1 year service labor warranty.

Environmental vacuums HEPA filter equipped 1 year parts replacement and service labor warranty.

Replacement parts guaranteed for 90 days from date of installation against defects in material and workmanship.

The 10 year poly component replacement warranty with 1 year service labor extends for a period of ten (10) years from the date of the original purchase of the Kent equipment by the original purchaser. This warranty will not cover damage attributable to the following:

- (1) Improper, unreasonable or negligent use or abuse of the equipment.
- (2) Use of equipment with hot water or high temperature above 130 degrees Fahrenheit (54 degrees centigrade).
- (3) "Warping", "Creeping", or "Distortion" of part so long as the same does not interfere with normal operation.
- (4) Abrasions or punctures of the equipment.

The start date of the warranty coverage shall be the purchase date of the original end user or six months from the date the machine was shipped from the factory, whichever comes first.

PARTS OF KENT EQUIPMENT NOT COVERED BY WARRANTY

Certain parts of Kent equipment require replacement in the ordinary course of use due to normal wear by reason of their characteristics. These are normal wear items such as cords, gaskets, switches, bumpers, carbon brushes, handle grips, bags, hoses, bearings, etc.

EXCEPTIONS AND EXCLUSIONS FROM WARRANTY

This equipment is required to be used on electric current as indicated on the data plate. Otherwise damage, defects, malfunctions or other failures of the equipment arising from use on electric current not as indicated are excepted and excluded from this warranty. Defects, malfunctions, failure or damage of the equipment caused by improper, unreasonable or negligent use or abuse while in the possession of the purchaser are likewise excluded from this warranty. If repair is done on your equipment by anyone other than those designated as authorized to perform such work without first having obtained factory instructions, The Kent Company, at its sole option, may determine that this warranty will not apply and that reimbursement for such repair will not be made because of the failure to comply with such factory specified instructions.

PROCEDURE TO BE TAKEN TO OBTAIN PERFORMANCE OF WARRANTY REPAIR

To secure repair of the equipment or any warranted parts under this warranty, the following procedure should be taken. The inoperative equipment or warranted parts, together with satisfactory evidence of the purchase date, must be delivered, with shipping and delivery charges prepaid, to one of the following:

- (1) The dealer from whom purchased;
- (2) Any Kent distributor's service department in the United States;
- (3) Any Kent authorized service station in the United States.

If you are unable to locate any of the foregoing, you may write or otherwise communicate with The Kent Company for instructions before repair service is performed by anyone else. In such event, The Kent Company will provide either the location of a closely available Kent distributor service department or Kent authorized service station or other factory instructions. Upon compliance with the above procedure, all warranted defects will be repaired, at no additional charge or costs to the customer, and the repaired product returned to the customer, with all shipping and delivery charges prepaid. In following the procedures above set forth, PLEASE MAKE CERTAIN to state the Kent model, type and serial number as shown on the dataplate of the equipment.

REPLACEMENT

In the event of a defect, malfunction or failure of your Kent equipment or any warranted part to conform with this warranty, The Kent Company may, at its sole option and own expense, replace the equipment or any warranted part with another new identical or reasonably equivalent model or part in lieu of repairing the defect.

NO REFUND OF PURCHASE PRICE

The Kent Company will not, as a matter of its warranty policy, refund the customer's purchase price.

WARRANTY REGISTRATION CARD FOR YOUR KENT EQUIPMENT AND REQUEST FOR INFORMATION

Your Kent Company distributor from whom you purchased your equipment is responsible for the registration of your warranty with the factory. We ask that you cooperate with your distributor in supplying the necessary information on the warranty card so that we may better serve you. Any information or questions you may have concerning your Kent equipment or this warranty may likewise be secured from the factory. This warranty gives you specific legal rights, and you may also have other rights which vary from state to state

THE KENT COMPANY

P.O. BOX 1665 ELKHART, INDIANA 46515