



Electronic Service Manuals

This electronic document is provided as a service to our customers. We do not create the contents of the information contained in this document. Should you have detailed questions pertaining to the information contained in this document, you may contact Michco, or the manufacturer which provided the original information in this electronic deliverable. Michco's only part in this electronic deliverable was the electronic assembly process. By providing this manual on line we are not guaranteeing parts availability.

You may contact Michco through the following methods:

Phone (517) 484-9312 or (800) 331-3339

2011 N. High St. -- Lansing, Michigan -- 48906

Fax: (517) 484-9836

Email: CustServe@Michco.com

Web site: www.Michco.Com

Parts Web site: www.FloorMachineParts.Com

Order Parts on Line at:

www.FloorMachineParts.Com

Directly to Parts & Service:

By Email: **Shop@Michco.com**

By Fax: (517) 702-2041

By Voice: Use numbers above.

Serving the Cleaning Industry Since 1922

Notice: All copyrighted material remains property of original owners, all trademarks are property of respective owners. Manuals are subject to Manufacturer's reproduction limitations. Originals or reproductions were provided by manufacturers through a request. We make no warranty as to the correctness of information provided in this document and you assume all risk. By placing these manuals on line we are not declaring our corporation to be an manufacturer authorized dealer or provider, please check our web site for authorized manufacturers we represent.

Toughman™ 21" Battery Strip Machine

OPERATOR'S MANUAL

Item #87059-00

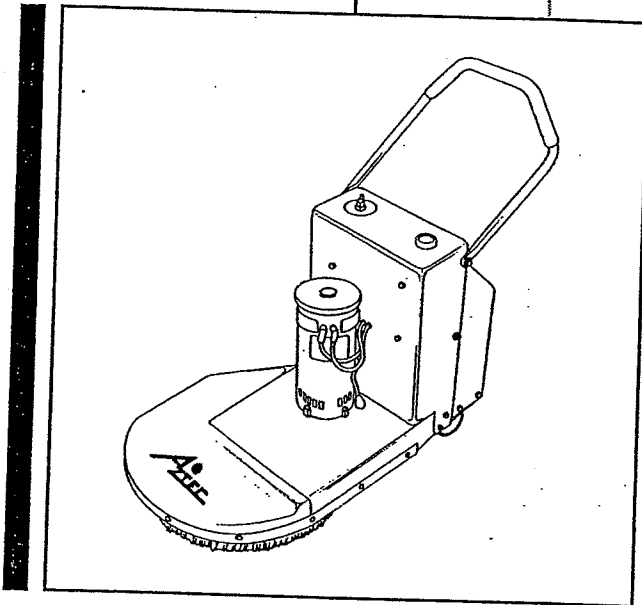

Chemicals
Equipment
Programs
Process

BETCO®

TOUGHMAN 21 Battery Stripping Machine

I. ELECTRICAL EQUIPMENT PREPARATION

- A. Familiarize yourself with equipment by reading manuals and identifying components and controls.
- B. Familiarize yourself with suggested maintenance schedule. Equipment is equipped with an hour/maintenance meter to aid in preventive maintenance.
- C. Never let an untrained person operate or perform repairs on equipment. Damage may result to floor, equipment or persons.
- D. Never change or alter electric controls of equipment. If repairs must be done, only trained personnel should do so. Always disconnect batteries during repairs. Wear face shield, gloves and apron when servicing or removing batteries.

II. MOTOR MAINTENANCE

- A. Lubrication - This motor is supplied with pre-lubricated ball bearings - lubricated for the life of the bearings.
- B. Motor Brushes - Need periodic inspection and replacement as wear indicates. It is recommended that brush wear be checked at early intervals of operation in order to determine future inspection. Brushes have an initial length of 1-1/4" and should be replaced at 5/8".

III. PAD DRIVER, BRUSH AND WHEEL ADJUSTMENT

- A. To replace pad driver assembly or add optional strip brush:
 - Adjust the handle to enable the Toughman to stand on rear wheels. **Never turn machine on its side.** Handle must be in shipping (forward) position to insure stability in the "tilt back" position.
 - Lean machine back on main handle. A second person should assist to be sure machine does not fall forward.
- C. When using pad driver system, wheels should be located on lower set of holes closest to the floor.
- B. Depending on what kind of surfaces the equipment is used on, ceramic tile, or vinyl tile, brush life should range from 500,000 - 1,000,000 sq. ft. As the brush wears, the nose of the machine will lean slightly forward, causing the brush to wear unevenly. The bristles on a new brush are approximately 1-1/2" long. When the bristles wear to approximately 3/4" - 1", move the wheels to the upper wheel mount holes. This will allow for extended brush life and allow equipment to be more efficient.

IV. TROUBLE SHOOTING THE ELECTRICAL SYSTEM

- A. Be careful not to touch the exterior of an operating motor. It may be hot enough to cause injury.
- B. If circuit breaker has been tripped, push the Reset Button. If breaker keeps tripping, check all wires and connections for obvious problems. If no problems are found, check for unusual binding or mechanical load.

V. 24V TOUGHMAN OPERATION

- A. To start 24V motor, turn Master Disconnect Switch to "ON" position. Brush will start to rotate.
- B. Push machine straight ahead at normal walking speed.
 - Do not use on surfaces with a gradient exceeding 2%.
 - Never tilt back machine to maintenance position while motor is running.
 - Never reach under machine deck while motor is running.

VI. PAD AND BRUSH OPTIONS

- A. A Pad Driver assembly with 1" clear nylon bristles is supplied as standard equipment on the Toughman. Also available is a Strata Grit Brush with 1 1/2" red Strata Grit Bristles. Depending on application, either can be used. The pad driver (with 1" clear nylon bristles), is not to be used to scrub or strip. The pad driver is only intended to hold the HighPro Pad. The pad driver with the 3M H. Pro Pad will be the most efficient on vinyl tile.

VII. PAD DRIVER, BELT, IDLER PULLEY, OR DRIVE SHAFT REPLACEMENT:

- A. Adjust the handle to enable the Toughman to stand on rear wheels. **Never turn machine on its side.**
 - Handle must be in shipping (forward) position to insure stability in the "tilt back" position. A second person should aide in the lift and to secure the machine while being serviced.
 - Do not use handle when attempting to tilt back machine for service or cleaning. Handle is designed for control during operation — Do not use excessive vertical pressure.
- B. Remove brush nut & brush centering device.
- C. Remove pad driver. (Replace if worn.)
- D. Remove idler pulley. (Replace if worn.)
- E. Remove belt(s). (Replace if worn.)

F. To remove driveshaft unit: Remove retaining bolt & clip—pull driveshaft out of housing—use of a slide hammer may assist in removal (Do not pry with crow bar). While drive shaft is removed, spin bearings. If roughness is felt, bearing replacement may be necessary.

G. To reassemble, reverse order of all steps taken above.

NOT ALL OF THESE STEPS WILL BE NECESSARY FOR ALL JOBS, BUT IF THEY ARE, THE ENTIRE JOB CAN BE COMPLETED QUICKLY WITH A FEW TOOLS.

VIII. BATTERIES:

A. The Toughman comes with two 12V gel cycle type batteries. This eliminates the possibility of acid spill when the machine is tipped over for service or shipment.

B. The original batteries are Deka #8G24MM weighing 54# each. Dimensions: 10 7/8" L, 6 3/4" W, 9 7/8" H.

C. PROPER CARE AND USE OF BATTERIES:

CAUTION: Always wear protective eye shields and clothing when working with batteries. Do not put wrenches or other metal objects across the battery terminal or battery top — arcing or explosion of the battery can result. Do not wear jewelry when working around batteries — arcing can cause severe burns.

- **New batteries will not deliver their full performance until after several cycles.**
- **The tops of the batteries and battery terminals must be kept clean and dry at all times to prevent excessive self discharge and flow of current between the battery post and frame.**
- **Do not over discharge the batteries. Excessive discharge can cause polarity reversal of individual cells resulting in complete battery failure.**

IX. CHARGER:

A. The Toughman is equipped with an on board charger designed specifically for re-charging gel cycle type batteries.

B. NORMAL OPERATION:

1. Plug the charger into AC power having the same rating as that of the charger (ie: 120 volts).
2. The LED on the charger will light, indicating charge current is flowing.
3. Batteries are brought to the gassing threshold, (2.3 volts per cell) at the same time charge current is tapering. When the charge indicator LED begins to blink, batteries can be assumed to be 80% charged. The charger should be left on for at least an hour more to be assured

of fully charged batteries. Eventually current should diminish to below one amp if all cells in the battery are good. The charger can be left connected indefinitely.

4. To discontinue charging, unplug the AC power cord. Plugging the AC power back in will cause the charger to repeat the cycle.

▲ WARNING: Do not disconnect the DC output leads or unplug the connector from the batteries when the charger is on. The resulting arcing could cause the batteries to explode. If the charger must be stopped, unplug the AC power.

▲ WARNING: Failure to unplug AC power before moving or driving equipment will result in damage to cords, plugs and receptacles.

▲ WARNING: Chargers can ignite flammable materials and vapors. Do not use near fuels, grain, dust, solvents, or other flammables.

▲ WARNING: To reduce the risk of fire, use this charger only on circuits provided with a maximum of 20 ampere branch circuit protection (circuit breaker or fuse), in accordance with the National Electric Code, ANSI/NFPA 70, and all local codes and ordinances.

C. **GROUNDING INSTRUCTIONS** – This battery charger must be grounded to reduce the risk of electric shock. The charger is equipped with a grounding type plug, it must be plugged into a nominal 115V, 60 Hertz circuit.

▲ WARNING: Improper connection of the equipment grounding conductor can result in the risk of an electric shock. **DO NOT USE THIS CHARGER ON A TWO POLE UNGROUNDED OUTLET OR ATTEMPT TO BREAK OFF THE GROUND PRONG FOR USE ON A RECEPTACLE OR EXTENSION CORD NOT HAVING A GROUND.**

The use of an extension cord with this charger should be avoided. The use of an improper extension cord could result in the risk of a fire or electric shock. If an extension cord must be used, make sure it is in good condition. Use a three conductor cord no smaller than 14 AWG. Keep it as short as possible. Locate all cords so that they will not be stepped on, tripped over, or otherwise subjected to damage or stress.

▲ WARNING: Make sure the DC output leads, terminals or connectors are all in good working condition.

DO NOT USE THIS CHARGER IF:

The DC output connector (if equipped) is loose or does not make good contact; is cracked or broken; the leads are cut or have exposed wire; the DC output leads or connector feel hot when used.

PG. 4 BATTERY TOUGHMAN

Using this charger with any of the previously described symptoms could result in a fire, property damage, or personal injury. Have a qualified service person make the necessary repairs. Repairs should not be made by people who are not qualified.

D. TROUBLE SHOOTING CHARGER

▲ CAUTION: DO NOT DISASSEMBLE THE CHARGER. Incorrect assembly may result in a risk of electric shock or fire. Contact factory.

▲ DANGER: To reduce the risk of electric shock, always disconnect both the AC power supply cord and the output leads or connector before attempting any maintenance cleaning.

1. **LED DOES NOT COME ON WHEN POWER IS APPLIED** – Be sure you are plugged into a live circuit; check the AC cord for breaks in the cord or plug; check the DC leads for breaks; check the DC connections to the battery, clean if heavily corroded.

Place a volt meter across the battery terminals where the charger is connected. Apply AC power. If the voltage rises on the battery, the charger is working and the LED is defective. Note: LEDs do not burn out, but it has probably received a sharp blow causing physical damage. No harm will come from operating the charger without a working LED.

2. **LED NEVER BLINKS** – The batteries have one or more shorted cells which are not allowing the charger current to decline low enough to start the LED blinking. Overheating of the defective cell and excessive water usage are symptoms of this condition. Replace defective battery.
3. **AC LINE FUSE OR CIRCUIT BREAKER BLOWS** – Either the circuit breaker or fuse is weak, or the charger is shorted internally.
4. **NO POWER IS PRESENT ACROSS THE DC LEADS WHEN A VOLT METER IS CONNECTED** – Good. The charger will not turn on until leads are connected, correct polarity to the battery.
5. **BATTERIES DO NOT RECEIVE FULL CHARGE** – The battery you are charging may be too large for the charger, or if you have the charger plugged into a long extension cord that is too small, a voltage drop will cause a decrease in charger output, extending charge times. If you are charging deep cycle batteries that need to be gassed, this charger will not charge beyond the gassing threshold.

BATTERY TOUGHMAN 24V WIRING DIAGRAM

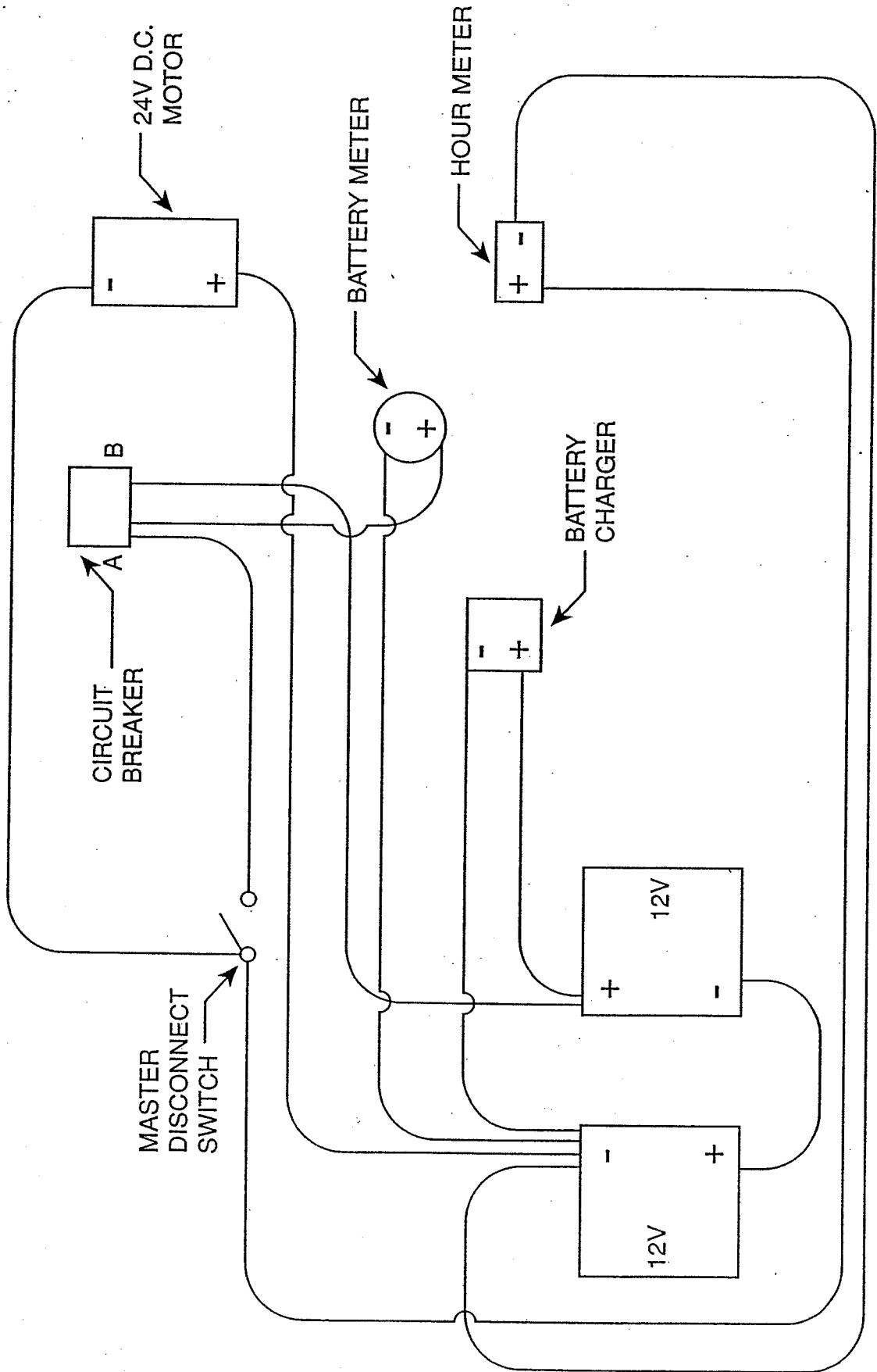

BATTERY TOUGHMAN PARTS SCHEMATIC

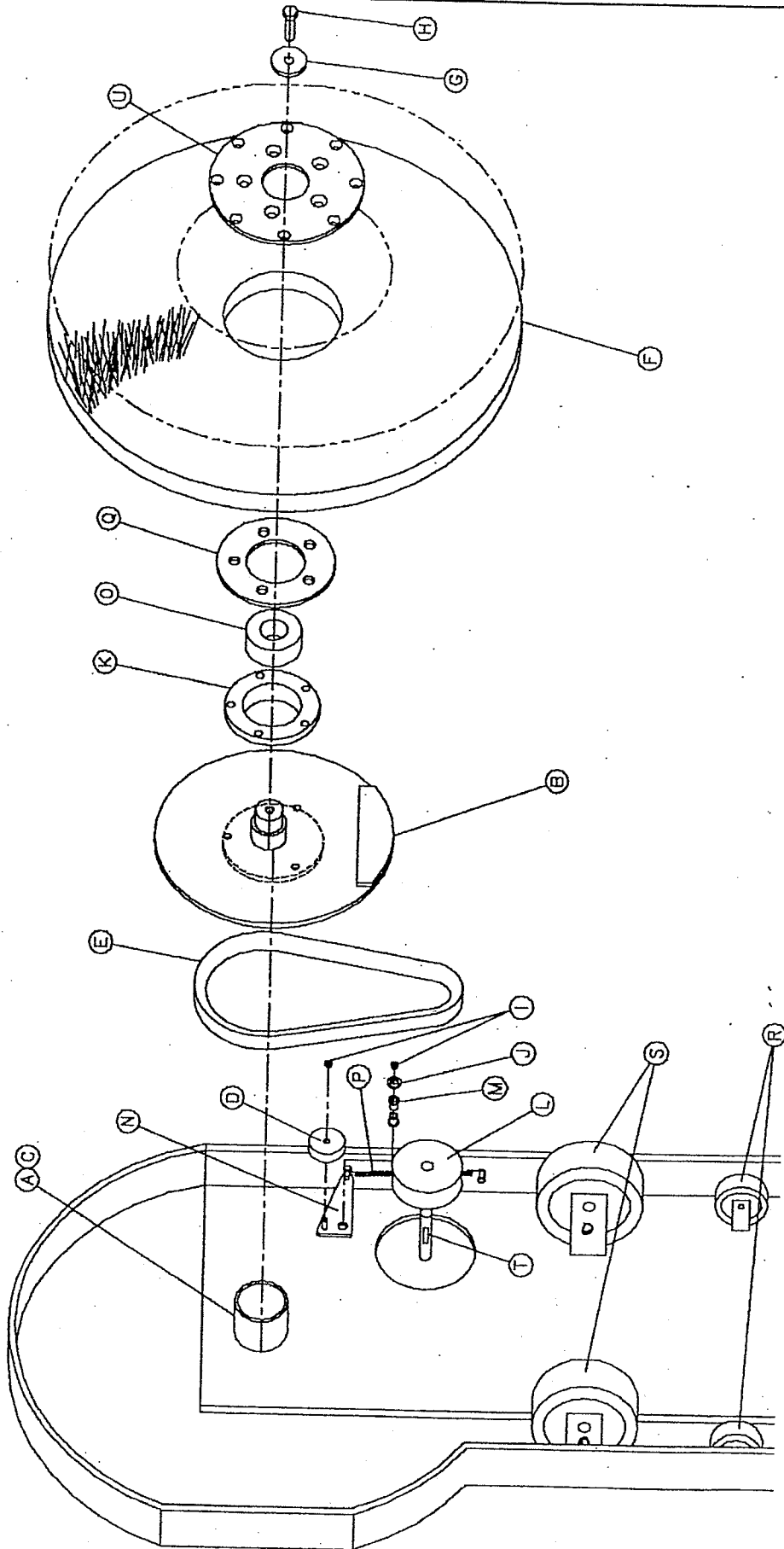

PART LIST FOR TOUGHMAN 21

PART	DESCRIPTION	PART NUMBER	QTY	NOTES
A	BEARING CAPTURE	N/A	1	
B	DRIVE SHAFT	024-772DS	1	
C	SET SCREW	164-10003	1	1/4x20x1/2" BOLT
D	V-IDLER PULLEY	188-V42B	1	
E	DRIVE BELT	113-L536	1	
F	BRUSH 20"	201-20000SP	1	
G	BRUSH HOLDER PLATE	024-700	1	
H	BOLT	164-10117	4	3/8"-16x1 1/4 BOLT
I	HEX NUT	164-22004	3	3/8"-16 HEX NUT
J	FLAT WASHER	164-20156	2	5/16" FLAT WASHER
K	BEARING HOUSING	024-100	1	
L	CRANK PULLEY	172-BC36x7/8"	1	
M	NYLON BUSHING	196-71200	2	
N	CLUTCHING IDLER	024-962I	1	
O	BEARING	024-200	1	
P	SPRING	173-7599-DWG	1	.085-.75(OD)x7" SPRING
Q	SPACER	024-300	1	
R	POLY WHEEL	156-PB-03041-08	2	3x1.25 POLYOFIN WHEEL
S	5" WHEEL	156-ACPLY-5J3	2	
T	KEY	199-NHNT-SE-UND	1	1/4" SQUARE KEY
U	BRUSH ADAPTER PLATES	024-400	1	